

Beneficiar: comuna Murgasi , jud. Dolj
 Executant:
 Proiectant:
 Obiectivul: Modernizare infrastructura rutiera comuna Murgasi, judetul Dolj
 Obiectul: 4 STRADA BISERICII GAIA TRONSON 2
 Stadiul fizic: 1.1 Strat inferior de fundatie din balast ., in grosime de 20 cm



Formular F3 Lista cu cantitati de lucrari pe categorii de lucrari

SECTIUNEA TEHNICA				SECTIUNEA FINANCIARA	
Nr.	Capitol de lucrari	U.M.	Cantitatea	Pretul unitar (fara TVA) - Lei -	TOTALUL (fara TVA) - Lei -
0	1	2	3	4	5 = 3 x 4
1	DA06B1 - Strat de agregate naturale cilindrate, avand functia de rezidenta filtranta, izolatoare, antigeliva si anticapilara, cu asternere mecanica;	mc	39.00		
			material:		
			manopera:		
			utilaj:		
			transport:		
1.1	2200393 - Balast sortat nespalat de rau 0-63 mm	mc	51.13		
1.2	6202806 - Apa industriala in cisterne pentru lucrari de drumuri si terasamente	mc	9.05		
1.3	24100 - Pavator	ora	14.43		
1.4	3546 - Autogreder pina la 175cp	ora	1.87		
1.5	4005 - Compactor static autoprop.cu rulouri(valturi),R8-14;de 14tf	ora	5.97		
1.6	5603 - Autocisterna cu dispozitiv de stropire cu M.a.J. pentru cantitati de 5-8 tone	ora	0.90		
2	TRA01A50 - Transportul rutier al materialelor,semifabricatelor cu autobasculanta pe dist.= 50 km. \$	tona	81.81		
			material:		
			manopera:		
			utilaj:		
			transport:		
2.1	8888988 - Transportul rutier al materialelor,semifabricatelor cu autobasculanta pe	tona	81.81		
3	TRA01A02 - Transportul rutier al materialelor,semifabricatelor cu autobasculanta pe dist.= 2 km. \$	tona	9.05		
			material:		
			manopera:		
			utilaj:		
			transport:		
3.1	8888892 - Transportul rutier al materialelor,semifabricatelor cu autobasculanta pe	tona	9.05		

TOTAL 1 (Cheltuieli directe)

Greutate Materiale (tone)	Ore Manopera	Material	Manopera	Utilaj	Transport	TOTAL

Recapitulatie	Valoare	Material	Manopera	Utilaj	Transport	TOTAL

Alte cheltuieli directe						
Contribuția asiguratorie pentru muncă						
T2 = T1 + Alte cheltuieli directe						

Recapitulatie	Valoare	Material	Manopera	Utilaj	Transport	TOTAL
Cheltuieli indirecte						
Cheltuieli indirecte						
T3 = T2 + Cheltuieli indirecte						
Beneficiu						
Profit						
T4 = T3 + Beneficiu						
TOTAL GENERAL (fara TVA)						
TVA (19.00%)						
TOTAL GENERAL (inclusiv TVA)						

Director

Sef proiect

Ofertant



Beneficiar: comuna Murgasi , jud. Dolj
 Executant:
 Proiectant:
 Obiectivul: Modernizare infrastructura rutiera comuna Murgasi, judetul Dolj
 Obiectul: 4 STRADA BISERICII GAIA TRONSON 2
 Stadiul fizic: 1.2 Strat superior de fundatie din piatra sparta, in grosime de 15 cm



Formular F3

Lista cu cantitati de lucrari pe categorii de lucrari

SECTIUNEA TEHNICA				SECTIUNEA FINANCIARA	
Nr.	Capitol de lucrari	U.M.	Cantitatea	Pretul unitar (fara TVA) - Lei -	TOTALUL (fara TVA) - Lei -
0	1	2	3	4	5 = 3 x 4
1	DA12B1 - Strat de fundatie sau reprofilare din piatra sparta pentru drumuri, cu asternere mecanica executate cu impanare fara innoroire;	mc	29.25		
			material:		
			manopera:		
			utilaj:		
			transport:		
1.1	2201658 - Piatra sparta pentru drumuri R.magmatice 15-25 MM.	mc	5.94		
1.2	2201672 - Piatra sparta pt drumuri R.magmatice 40-63 MM.	mc	35.66		
1.3	6202806 - Apa industriala in cisterne pentru lucrari de drumuri si terasamente	mc	4.39		
1.4	24100 - Pavator	ora	17.55		
1.5	3546 - Autogreder pina la 175cp	ora	1.23		
1.6	4005 - Compactor static autoprop.cu rulouri(valturi),R8-14;de 14tf	ora	7.55		
1.7	5603 - Autocisterna cu dispozitiv de stropire cu M.a.J. pentru cantitati de 5-8 tone	ora	0.44		
2	TRA01A50 - Transportul rutier al materialelor,semifabricatelor cu autobasculanta pe dist.= 50 km. \$	tona	62.39		
			material:		
			manopera:		
			utilaj:		
			transport:		
2.1	8888988 - Transportul rutier al materialelor,semifabricatelor cu autobasculanta pe	tona	62.39		
3	TRA05A02 - Transport rutier materiale,semifabricate cu autovehic.speciale(cisterna,beton.etc)pe dist.de 2 km.\$	tona	4.39		
			material:		
			manopera:		
			utilaj:		
			transport:		
3.1	30227 - Transport rutier materiale,semifabricate cu autovehic.speciale(cisterna,beton.etc)pe dist.de 2	tona	4.39		

TOTAL 1 (Cheltuieli directe)

Greutate Materiale (tone)	Ore Manopera	Material	Manopera	Utilaj	Transport	TOTAL
Recapitulatie	Valoare	Material	Manopera	Utilaj	Transport	TOTAL
Alte cheltuieli directe						

Recapitulatie	Valoare	Material	Manopera	Utilaj	Transport	TOTAL
Contribuția asiguratorie pentru muncă						
T2 = T1 + Alte cheltuieli directe						

Cheltuieli indirecte						
Cheltuieli indirecte						
T3 = T2 + Cheltuieli indirecte						

Beneficiu						
Profit						
T4 = T3 + Beneficiu						

TOTAL GENERAL (fara TVA)	
TVA (19.00%)	
TOTAL GENERAL (inclusiv TVA)	

Director

Sef proiect

Ofertant



Beneficiar: comuna Murgasi , jud. Dolj
 Executant:
 Proiectant:
 Obiectivul: Modernizare infrastructura rutiera comuna Murgasi, judetul Dolj
 Obiectul: 4 STRADA BISERICII GAIA TRONSON 2
 Stadiul fizic: 1.3 Strat de legatura din beton asfaltic deschis BADPC 22.4



Formular F3

Lista cu cantitati de lucrari pe categorii de lucrari

SECTIUNEA TEHNICA				SECTIUNEA FINANCIARA	
Nr.	Capitol de lucrari	U.M.	Cantitatea	Pretul unitar (fara TVA) - Lei -	TOTALUL (fara TVA) - Lei -
0	1	2	3	4	5 = 3 x 4
1	DB01B1 - Curatirea mecanica in vederea aplicarii imbracamintilor sau tratamentelor bituminoase a straturilor suport alcatuite din : macadam sau pavaj de piatra, nebitumat, executata cu perie mecanica;	mp	195.00		
			material:		
			manopera:		
			utilaj:		
			transport:		
1.1	6202806 - Apa industrială in cisterne pentru lucrari de drumuri si terasamente	mc	0.98		
1.2	4026 - Perie mec pt curatat fundatii drumuri 6 cp	ora	0.12		
1.3	5603 - Autocisterna cu dispozitiv de stropire cu M.a.J. pentru cantitati de 5-8 tone	ora	0.10		
2	DB02D1 - Amorsarea suprafetelor straturilor de baza sau a imbracamintilor existente in vederea aplicarii unui strat de uzura din mixtura asfaltica, executata cu: emulsie cationica cu rupere rapida	100 mp	1.95		
			material:		
			manopera:		
			utilaj:		
			transport:		
2.1	2600323 - Emulsie de bitum cationica cu rupere rapida S8877	kg	88.72		
3	DB12B1 - Strat de legatura (binder) de criblura executata la cald cu asternere mecanica	tona	30.26		
			material:		
			manopera:		
			utilaj:		
			transport:		
3.0	20020391 - BETON ASFALTIC DESCHIS pietris concasat tip BADPC 22,4	t	30.35		
4	TRA01A50 - Transportul rutier al materialelor,semifabricatelor cu autobasculanta pe dist.= 50 km. \$	tona	30.35		
			material:		
			manopera:		
			utilaj:		
			transport:		
4.1	8888988 - Transportul rutier al materialelor,semifabricatelor cu autobasculanta pe	tona	30.35		
5	TRA05A02 - Transport rutier materiale,semifabricate cu autovehic.speciale(cisterna,beton.etc)pe dist.de 2 km.\$	tona	1.06		
			material:		
			manopera:		
			utilaj:		
			transport:		

SECTIUNEA TEHNICA				SECTIUNEA FINANCIARA	
Nr.	Capitol de lucrari	U.M.	Cantitatea	Pretul unitar (fara TVA) - Lei -	TOTALUL (fara TVA) - Lei -
0	1	2	3	4	5 = 3 x 4
5.1	30227 - Transport rutier materiale, semifabricate cu autovehic. speciale (cisterna, beton, etc) pe dist. de 2	tona	1.06		

TOTAL 1 (Cheltuieli directe)

Greutate Materiale (tone)	Ore Manopera	Material	Manopera	Utilaj	Transport	TOTAL

Recapitulatie	Valoare	Material	Manopera	Utilaj	Transport	TOTAL

Alte cheltuieli directe						
Contribuția asiguratorie pentru muncă						
T2 = T1 + Alte cheltuieli directe						

Cheltuieli indirecte						
Cheltuieli indirecte						
T3 = T2 + Cheltuieli indirecte						

Beneficiu						
Profit						
T4 = T3 + Beneficiu						

TOTAL GENERAL (fara TVA)	
TVA (19.00%)	
TOTAL GENERAL (inclusiv TVA)	

Director

Sef proiect

Ofertant



Beneficiar: comuna Murgasi , jud. Dolj
 Executant:
 Proiectant:
 Obiectivul: Modernizare infrastructura rutiera comuna Murgasi, judetul Dolj
 Obiectul: 4 STRADA BISERICII GAIA TRONSON 2
 Stadiul fizic: 1.4 Strat de uzura din BAPC 16-4 cm grosime



Formular F3 Lista cu cantitati de lucrari pe categorii de lucrari

SECTIUNEA TEHNICA				SECTIUNEA FINANCIARA	
Nr.	Capitol de lucrari	U.M.	Cantitatea	Pretul unitar (fara TVA) - Lei -	TOTALUL (fara TVA) - Lei -
0	1	2	3	4	5 = 3 x 4
1	DB01A1 - Curatirea mecanica in vederea aplicarii imbracamintilor sau tratamentelor bituminoase a straturilor suport alcatuite din : suprafete bituminoase din beton cimentat sau pavaje din piatra bitumate, executata cu peria mecanica;	mp	195.00		
			material:		
			manopera:		
			utilaj:		
			transport:		
1.1	6202806 - Apa industriala in cisterne pentru lucrari de drumuri si terasamente	mc	0.58		
1.2	4026 - Perie mec pt curatat fundatii drumuri 6 cp	ora	0.06		
1.3	5603 - Autocisterna cu dispozitiv de stropire cu M.a.J. pentru cantitati de 5-8 tone	ora	0.06		
2	DB02D1 - Amorsarea suprafetelor straturilor de baza sau a imbracamintilor existente in vederea aplicarii unui strat de uzura din mixtura asfaltica, executata cu: emulsie cationica cu rupere rapida	100 mp	1.95		
			material:		
			manopera:		
			utilaj:		
			transport:		
2.1	2600323 - Emulsie de bitum cationica cu rupere rapida S8877	kg	88.72		
3	DB16H1 - Imbracaminte de beton asfaltic cu agregate marunte executata la cald, in grosime de : 4,0 CM cu asternere mecanica	mp	195.00		
			material:		
			manopera:		
			utilaj:		
			transport:		
3.0	20060395 - BETON ASFALTIC cu pietris concasat tip BAPC 16	t	18.33		
4	TRA01A50 - Transportul rutier al materialelor,semifabricatelor cu autobasculanta pe dist.= 50 km. \$	tona	18.33		
			material:		
			manopera:		
			utilaj:		
			transport:		
4.1	8888988 - Transportul rutier al materialelor,semifabricatelor cu autobasculanta pe	tona	18.33		
5	TRA05A02 - Transport rutier materiale,semifabricate cu autovehic.speciale(cisterna,beton.etc)pe dist.de 2 km.\$	tona	0.67		
			material:		
			manopera:		
			utilaj:		
			transport:		

SECTIUNEA TEHNICA				SECTIUNEA FINANCIARA	
Nr.	Capitol de lucrari	U.M.	Cantitatea	Pretul unitar (fara TVA) - Lei -	TOTALUL (fara TVA) - Lei -
0	1	2	3	4	5 = 3 x 4
5.1	30227 - Transport rutier materiale,semifabricate cu autovehic.speciale(cisterna,beton.etc)pe dist.de 2	tona	0.67		

TOTAL 1 (Cheltuieli directe)

Greutate Materiale (tone)	Ore Manopera	Material	Manopera	Utilaj	Transport	TOTAL

Recapitulatie	Valoare	Material	Manopera	Utilaj	Transport	TOTAL

Alte cheltuieli directe						
Contribuția asiguratorie pentru muncă						
T2 = T1 + Alte cheltuieli directe						

Cheltuieli indirecte						
Cheltuieli indirecte						
T3 = T2 + Cheltuieli indirecte						

Beneficiu						
Profit						
T4 = T3 + Beneficiu						

TOTAL GENERAL (fara TVA)	
TVA (19.00%)	
TOTAL GENERAL (inclusiv TVA)	

Director

Sef proiect

Ofertant



Beneficiar: comuna Murgasi , jud. Dolj
 Executant:
 Proiectant:
 Obiectivul: Modernizare infrastructura rutiera comuna Murgasi, judetul Dolj
 Obiectul: 4 STRADA BISERICII GAIA TRONSON 2
 Stadiul fizic: 2.1 Marcaje rutiere longitudinale



Formular F3 Lista cu cantitati de lucrari pe categorii de lucrari

SECTIUNEA TEHNICA				SECTIUNEA FINANCIARA	
Nr.	Capitol de lucrari	U.M.	Cantitatea	Pretul unitar (fara TVA) - Lei -	TOTALUL (fara TVA) - Lei -
0	1	2	3	4	5 = 3 x 4
1	DF16A1 - Marcaje rutiere longitudinale, simple sau duble, cu intreruperi sau continue, executate mecanizat cu vopsea de email cu microbule de sticla;	km	0.14		
			material:		
			manopera:		
			utilaj:		
			transport:		
1.1	2600206 - Bitum pt drumuri tip D 80/120 stas 754	kg	0.17		
1.2	6108804 - Email alb II E.109-5 ni 1707-61	kg	7.06		
1.3	6109418 - Diluant ptr produse de marcare D009-3 ni 1708-61 a9	kg	0.35		
1.4	6200676 - White spirit rafinat tip a stas 44	kg	0.11		
1.5	7329912 - Microbule sticla semnaliz.orient albe D = 02-05 MM.	kg	2.37		
1.6	2200525 - Nisip de rau si lacuri sortat si nespalat, 0.0-7.00 mm	mc	0.00		
1.7	10200 - Asfaltator	ora	0.46		
1.8	4062 - Masina de trasat benzi de circulatie motor ardere interna 40-45cp	ora	0.04		

TOTAL 1 (Cheltuieli directe)

Greutate Materiale (tone)	Ore Manopera	Material	Manopera	Utilaj	Transport	TOTAL

Recapitulatie	Valoare	Material	Manopera	Utilaj	Transport	TOTAL

Alte cheltuieli directe						
Contribuția asiguratorie pentru muncă						
T2 = T1 + Alte cheltuieli directe						

Cheltuieli indirecte						
Cheltuieli indirecte						
T3 = T2 + Cheltuieli indirecte						

Beneficiu						
Profit						
T4 = T3 + Beneficiu						

TOTAL GENERAL (fara TVA)	
TVA (19.00%)	
TOTAL GENERAL (inclusiv TVA)	

Director

Sef proiect

Ofertant



Beneficiar: comuna Murgasi , jud. Dolj
 Executant:
 Proiectant:
 Obiectivul: Modernizare infrastructura rutiera comuna Murgasi, judetul Dolj
 Obiectul: 4 STRADA BISERICII GAIA TRONSON 2
 Stadiul fizic: 2.2 Indicatoare de circulatie



Formular F3 Lista cu cantitati de lucrari pe categorii de lucrari

SECTIUNEA TEHNICA				SECTIUNEA FINANCIARA	
Nr.	Capitol de lucrari	U.M.	Cantitatea	Pretul unitar (fara TVA) - Lei -	TOTALUL (fara TVA) - Lei -
0	1	2	3	4	5 = 3 x 4
1	DF18A1 - Plantarea stilpilor pentru indicatoare de circulatie rutiera din : metal, confectionati industrial ;	buc	1.00		
			material:		
			manopera:		
			utilaj:		
			transport:		
1.1	10173 - Beton preparate	mc	0.10		
1.1.1	2100945 - Beton de ciment B 150 stas 3622	mc	0.10		
1.2	10826 - Stilp metalici ptr indicatoare	buc	1.00		
1.2.1	6301793 - Stilp metalic confectionat industrial	buc	1.00		
1.3	11000 - Betonist	ora	0.33		
1.4	20650 - Muncitor de deservire pentru montajul in constructii	ora	0.84		
2	DF19A1 - Montarea indicatoarelor pentru circulatia rutiera din tabla de otel sau aluminiu pe : un stalp gata plantat;	buc	1.00		
			material:		
			manopera:		
			utilaj:		
			transport:		
2.1	10821 - Indicatoare de circulatie	buc	1.00		
2.1.1	7101619 - Indicator circul.tbl.OL+fol.R.octogon H = 700MM F35 S1848	buc	1.00		
2.1	7100017 - Indicator circul.tbl.OL+fol.R. triunghi L = 700MM F 1 S1848	buc	0.00		
2.1	7100029 - Indicator circul.tbl.OL+fol.R. triunghi L = 700MM F 2 S1848	buc	0.00		
2.2	5800376 - Surub cap hexagonal precis M 6 X 25 GR. 5.8 S4272	buc	4.00		
2.3	5817446 - Surub cap hexagonal semiprecis M 8X 30 GR. 5.8 S 6220	buc	2.00		
2.4	5840405 - Piulita hexagonala grosolana 6 GR. 5 S 922	buc	4.00		
2.5	5840766 - Piulita hexagonala grosolana B m 8 GR. 5 S 922	buc	2.00		
2.6	5882142 - Saiba prec.plata pt.met a m 8 OL34 S 5200	kg	0.02		
2.7	5882489 - Saiba prec.plata pentru met B m 6 OL 34 S 5200	kg	0.04		
2.8	13430 - Dulgher poduri	ora	0.22		
2.9	20640 - Muncitor deservire constructii masini	ora	0.22		

SECTIUNEA TEHNICA				SECTIUNEA FINANCIARA	
Nr.	Capitol de lucrari	U.M.	Cantitatea	Pretul unitar (fara TVA) - Lei -	TOTALUL (fara TVA) - Lei -
0	1	2	3	4	5 = 3 x 4
3	TRA06A20 - Transportul rutier al betonului-mortarului cu autobetoniera de 5,5MC dist. =20km \$	tona	0.24		
			material:		
			manopera:		
			utilaj:		
			transport:		
3.1	30295 - Transportul rutier al betonului-mortarului cu autobetoniera de 5,5MC dist. = 20km	tona	0.24		
4	TRA02A50 - Transportul rutier al materialelor,semifabricatelor cu autocamionul pe dist.= 50 km.	tona	0.03		
			material:		
			manopera:		
			utilaj:		
			transport:		
4.1	8889039 - Transportul rutier al materialelor,semifabricatelor cu autocamionul pe dist.=	tona	0.03		

TOTAL 1 (Cheltuieli directe)

Greutate Materiale (tone)	Ore Manopera	Material	Manopera	Utilaj	Transport	TOTAL

Recapitulatie	Valoare	Material	Manopera	Utilaj	Transport	TOTAL

Alte cheltuieli directe						
Contribuția asiguratorie pentru muncă						
T2 = T1 + Alte cheltuieli directe						

Cheltuieli indirecte						
Cheltuieli indirecte						
T3 = T2 + Cheltuieli indirecte						

Beneficiu						
Profit						
T4 = T3 + Beneficiu						

TOTAL GENERAL (fara TVA)	
TVA (19.00%)	
TOTAL GENERAL (inclusiv TVA)	

Director

Sef proiect

Ofertant



Beneficiar: comuna Murgasi , jud. Dolj
 Executant:
 Proiectant:
 Obiectivul: Modernizare infrastructura rutiera comuna Murgasi, judetul Dolj
 Obiectul: 5 STRADA BISERICII MURGASI



CENTRALIZATORUL cheltuielilor pe categorii de lucrari, obiect

null

Nr.	Nr cap. Deviz General	Cheltuieli pe categoria de lucrari	Valoare (fara TVA)
			Lei
0	1	2	3

CAPITOL I

I. Constructii si instalatii

	4.1.1	Terasamente, sistematizare pe verticala si amenajari exterioare	
3	4.1.2	Rezistenta	
		1 Terasamente - sapatura	
		2.3 Strat de legatura din beton asfaltic deschis BADPC 22.4	
		2.4 Strat de uzura din BAPC 16-4 cm grosime	
		3.1 Marcaje rutiere longitudinale	
		3.2 Indicatoare de circulatie	
		2.1 Strat inferior de fundatie din balast ., in grosime de 20 cm	
		2.2 Strat superior de fundatie din piatra sparta, in grosime de 15 cm	
11	4.1.3	Arhitectura	
12	4.1.4	Instalatii	
13	4.1.5	Alte categorii de constructii	
TOTAL CAPITOL I			

CAPITOL II

II. Montaj

15	4.2	Montaj utilaje, echipamente tehnologice si functionale	
TOTAL CAPITOL II			

CAPITOL III

III. Procurare

17	4.3	Utilaje, echipamente tehnologice si functionale care necesita montaj	
18	4.4	Utilaje, echipamente tehnologice si functionale care nu necesita montaj si echipamente de transport	
19	4.5	Dotari	
20	4.6	Active necorporale	
TOTAL CAPITOL III			

CAPITOL IV

IV. Probe

22	6.2	Probe tehnologice si teste	
TOTAL CAPITOL IV			

TOTAL 5 STRADA BISERICII MURGASI (fara TVA)	
---	--

TOTAL 5 STRADA BISERICII MURGASI (cu TVA)	
---	--

Director

Sef proiect

Ofertant



Beneficiar: comuna Murgasi , jud. Dolj
 Executant:
 Proiectant:
 Obiectivul: Modernizare infrastructura rutiera comuna Murgasi, judetul Dolj
 Obiectul: 5 STRADA BISERICII MURGASI
 Stadiul fizic: 1 Terasamente - sapatura



Formular F3

Lista cu cantitati de lucrari pe categorii de lucrari

SECTIUNEA TEHNICA				SECTIUNEA FINANCIARA	
Nr.	Capitol de lucrari	U.M.	Cantitatea	Pretul unitar (fara TVA) - Lei -	TOTALUL (fara TVA) - Lei -
0	1	2	3	4	5 = 3 x 4
1	TSA01B1 - Sapatura manuala de pamant in spatii inchise la deblee, in canale deschise, in gropi de imprumut la indepartarea stratului vegetal de 10-30 CM grosime etc .in pamant cu umiditate naturala aruncarea in depozit sau vehicul la H<0.6 M teren mijlociu	mc	12.39		
			material:		
			manopera:		
			utilaj:		
			transport:		
1.1	26100 - Sapator	ora	9.54		
2	TRI1AA01C3 - Incarcarea materialelor, grupa a-grele si marunte, prin aruncare rampa sau teren-auto categ.3	tona	22.30		
			material:		
			manopera:		
			utilaj:		
			transport:		
2.1	20900 - Muncitor incarcare-descarcare materiale	ora	7.80		
3	TSC02D1 - Sapatura mecanica cu excavator pe pneuri de 0.12-0.39 mc, cu comanda hidraulica, in : pamant cu umiditate naturala descarcare auto in teren catg 2	100 mc	0.29		
			material:		
			manopera:		
			utilaj:		
			transport:		
3.1	3521 - Excavator pe pneuri motor termic(buldoexcavator)0,21-0,39MC	ora	1.38		
4	TRA01A05P - Transportul rutier al pamantului sau molozului cu autobasculanta dist.= 5 km	tona	73.34		
			material:		
			manopera:		
			utilaj:		
			transport:		
4.1	20640 - Muncitor deservire constructii masini	ora	0.00		
4.2	8888899 - Transportul rutier al pamintului sau molozului cu autobasculanta dist.= 5 km	tona	73.34		
5	TSD03E1 - Imprastierea pamantului afanat provenit din teren categoria 1 sau 2 si categoria 3 sau 4, executata cu buldozer pe tractor cu senile de 81-180 cp, in stratouri cu grosimea de : 31-50 CM, teren catg. 1 sau 2	100 mc	0.50		
			material:		
			manopera:		
			utilaj:		
			transport:		
5.1	3554 - Buldozer pe senile 81-180 cp	ora	0.13		

SECTIUNEA TEHNICA				SECTIUNEA FINANCIARA	
Nr.	Capitol de lucrari	U.M.	Cantitatea	Pretul unitar (fara TVA) - Lei -	TOTALUL (fara TVA) - Lei -
0	1	2	3	4	5 = 3 x 4
6	TSE06B1 - Pregatirea platformei de pamant in vederea asternerii unui strat izolator sau de reparatie dni nisip sau balast, prin nivelarea manuala si compactarea cu rulou compresor static autopropulsat, de 10-12 t, in: pamant coeziv	100 mp	6.20		
			material:		
			manopera:		
			utilaj:		
			transport:		
6.1	6202806 - Apa industrială în cisterne pentru lucrări de drumuri și terasamente	mc	6.20		
6.2	15130 - Finisor de terasamente	ora	33.72		
6.3	20650 - Muncitor de deservire pentru montajul în construcții	ora	22.29		
6.4	4004 - Compactor autoprop. cu rulou. (valturi) pînă la 12tf	ora	8.68		
7	TRA02A02 - Transportul rutier al materialelor, semifabricatelor cu autocamionul pe dist. = 2 km. \$	tona	6.20		
			material:		
			manopera:		
			utilaj:		
			transport:		
7.1	8888991 - Transportul rutier al materialelor, semifabricatelor cu autocamionul pe dist. =	tona	6.20		

TOTAL 1 (Cheltuieli directe)

Greutate Materiale (tone)	Ore Manopera	Material	Manopera	Utilaj	Transport	TOTAL

Recapitulatie	Valoare	Material	Manopera	Utilaj	Transport	TOTAL

Alte cheltuieli directe						
Contribuția asiguratorie pentru muncă						
T2 = T1 + Alte cheltuieli directe						

Cheltuieli indirecte						
..cheltuieli indirecte						
T3 = T2 + Cheltuieli indirecte						

Beneficiu						
Profit						
T4 = T3 + Beneficiu						

TOTAL GENERAL (fara TVA)	
TVA (19.00%)	
TOTAL GENERAL (inclusiv TVA)	

Director

Sef proiect

Ofertant



Beneficiar: comuna Murgasi , jud. Dolj
 Executant:
 Proiectant:
 Obiectivul: Modernizare infrastructura rutiera comuna Murgasi, judetul Dolj
 Obiectul: 5 STRADA BISERICII MURGASI
 Stadiul fizic: 2.1 Strat inferior de fundatie din balast ., in grosime de 20 cm



Formular F3 Lista cu cantitati de lucrari pe categorii de lucrari

SECTIUNEA TEHNICA				SECTIUNEA FINANCIARA	
Nr.	Capitol de lucrari	U.M.	Cantitatea	Pretul unitar (fara TVA) - Lei -	TOTALUL (fara TVA) - Lei -
0	1	2	3	4	5 = 3 x 4
1	DA06B1 - Strat de agregate naturale cilindrate, avand functia de rezidenta filtranta, izolatoare, antigeliva si anticapilara, cu asternere mecanica;	mc	82.60		
			material:		
			manopera:		
			utilaj:		
			transport:		
1.1	2200393 - Balast sortat nespalat de rau 0-63 mm	mc	108.29		
1.2	6202806 - Apa industriala in cisterne pentru lucrari de drumuri si terasamente	mc	19.16		
1.3	24100 - Pavator	ora	30.56		
1.4	3546 - Autogreder pina la 175cp	ora	3.96		
1.5	4005 - Compactor static autoprop.cu rulouri(valturi),R8-14;de 14tf	ora	12.64		
1.6	5603 - Autocisterna cu dispozitiv de stropire cu M.a.J. pentru cantitati de 5-8 tone	ora	1.90		
2	TRA01A50 - Transportul rutier al materialelor,semifabricatelor cu autobasculanta pe dist.= 50 km. \$	tona	173.26		
			material:		
			manopera:		
			utilaj:		
			transport:		
2.1	8888988 - Transportul rutier al materialelor,semifabricatelor cu autobasculanta pe	tona	173.26		
3	TRA01A02 - Transportul rutier al materialelor,semifabricatelor cu autobasculanta pe dist.= 2 km. \$	tona	19.16		
			material:		
			manopera:		
			utilaj:		
			transport:		
3.1	8888892 - Transportul rutier al materialelor,semifabricatelor cu autobasculanta pe	tona	19.16		

TOTAL 1 (Cheltuieli directe)

Greutate Materiale (tone)	Ore Manopera	Material	Manopera	Utilaj	Transport	TOTAL

Recapitulatie	Valoare	Material	Manopera	Utilaj	Transport	TOTAL

Alte cheltuieli directe						
Contribuția asiguratorie pentru muncă						
T2 = T1 + Alte cheltuieli directe						

Recapitulatie	Valoare	Material	Manopera	Utilaj	Transport	TOTAL
Cheltuieli indirecte						
Cheltuieli indirecte						
T3 = T2 + Cheltuieli indirecte						
Beneficiu						
Profit						
T4 = T3 + Beneficiu						
TOTAL GENERAL (fara TVA)						
TVA (19.00%)						
TOTAL GENERAL (inclusiv TVA)						

Director

Sef proiect

Ofertant



Beneficiar: comuna Murgasi , jud. Dolj
 Executant:
 Proiectant:
 Obiectivul: Modernizare infrastructura rutiera comuna Murgasi, judetul Dolj
 Obiectul: 5 STRADA BISERICII MURGASI
 Stadiul fizic: 2.2 Strat superior de fundatie din piatra sparta, in grosime de 15 cm



Formular F3 Lista cu cantitati de lucrari pe categorii de lucrari

SECTIUNEA TEHNICA				SECTIUNEA FINANCIARA	
Nr.	Capitol de lucrari	U.M.	Cantitatea	Pretul unitar (fara TVA) - Lei -	TOTALUL (fara TVA) - Lei -
0	1	2	3	4	5 = 3 x 4
1	DA12B1 - Strat de fundatie sau reprofilare din piatra sparta pentru drumuri, cu asternere mecanica executate cu impanare fara innoroire;	mc	61.95		
			material:		
			manopera:		
			utilaj:		
			transport:		
1.1	2201658 - Piatra sparta pentru drumuri R.magmatice 15-25 MM.	mc	12.58		
1.2	2201672 - Piatra sparta pt drumuri R.magmatice 40-63 MM.	mc	75.52		
1.3	6202806 - Apa industriala in cisterne pentru lucrari de drumuri si terasamente	mc	9.29		
1.4	24100 - Pavator	ora	37.17		
1.5	3546 - Autogreder pina la 175cp	ora	2.60		
1.6	4005 - Compactor static autoprop.cu rulouri(valturi),R8-14;de 14tf	ora	15.98		
1.7	5603 - Autocisterna cu dispozitiv de stropire cu M.a.J. pentru cantitati de 5-8 tone	ora	0.93		
2	TRA01A50 - Transportul rutier al materialelor,semifabricatelor cu autobasculanta pe dist.= 50 km. \$	tona	132.14		
			material:		
			manopera:		
			utilaj:		
			transport:		
2.1	8888988 - Transportul rutier al materialelor,semifabricatelor cu autobasculanta pe	tona	132.14		
3	TRA05A02 - Transport rutier materiale,semifabricate cu autovehic.speciale(cisterna,beton.etc)pe dist.de 2 km.\$	tona	9.29		
			material:		
			manopera:		
			utilaj:		
			transport:		
3.1	30227 - Transport rutier materiale,semifabricate cu autovehic.speciale(cisterna,beton.etc)pe dist.de 2	tona	9.29		

TOTAL 1 (Cheltuieli directe)

Greutate Materiale (tone)	Ore Manopera	Material	Manopera	Utilaj	Transport	TOTAL
Recapitulatie	Valoare	Material	Manopera	Utilaj	Transport	TOTAL
Alte cheltuieli directe						

Recapitulatie	Valoare	Material	Manopera	Utilaj	Transport	TOTAL
Contribuția asiguratorie pentru muncă						
T2 = T1 + Alte cheltuieli directe						

Cheltuieli indirecte						
Cheltuieli indirecte						
T3 = T2 + Cheltuieli indirecte						

Beneficiu						
Profit						
T4 = T3 + Beneficiu						

TOTAL GENERAL (fara TVA)	
TVA (19.00%)	
TOTAL GENERAL (inclusiv TVA)	

Director

Sef proiect

Ofertant



Beneficiar: comuna Murgasi , jud. Dolj
 Executant:
 Proiectant:
 Obiectivul: Modernizare infrastructura rutiera comuna Murgasi, judetul Dolj
 Obiectul: 5 STRADA BISERICII MURGASI
 Stadiul fizic: 2.3 Strat de legatura din beton asfaltic deschis BADPC 22.4



Formular F3

Lista cu cantitati de lucrari pe categorii de lucrari

SECTIUNEA TEHNICA				SECTIUNEA FINANCIARA	
Nr.	Capitol de lucrari	U.M.	Cantitatea	Pretul unitar (fara TVA) - Lei -	TOTALUL (fara TVA) - Lei -
0	1	2	3	4	5 = 3 x 4
1	DB01B1 - Curatirea mecanica in vederea aplicarii imbracamintilor sau tratamentelor bituminoase a straturilor suport alcatuite din : macadam sau pavaj de piatra, nebitumat, executata cu perie mecanica;	mp	413.00		
			material:		
			manopera:		
			utilaj:		
			transport:		
1.1	6202806 - Apa industriala in cisterne pentru lucrari de drumuri si terasamente	mc	2.06		
1.2	4026 - Perie mec pt curatat fundatii drumuri 6 cp	ora	0.25		
1.3	5603 - Autocisterna cu dispozitiv de stropire cu M.a.J. pentru cantitati de 5-8 tone	ora	0.21		
2	DB02D1 - Amorsarea suprafetelor straturilor de baza sau a imbracamintilor existente in vvederea aplicarii unui strat de uzura din mixtura asfaltica, executata cu: emulsie cationica cu rupere rapida	100 mp	4.13		
			material:		
			manopera:		
			utilaj:		
			transport:		
2.1	2600323 - Emulsie de bitum cationica cu rupere rapida S8877	kg	187.92		
3	DB12B1 - Strat de legatura (binder) de criblura executata la cald cu asternere mecanica	tona	64.10		
			material:		
			manopera:		
			utilaj:		
			transport:		
3.0	20020391 - BETON ASFALTIC DESCHIS pietris concasat tip BADPC 22,4	t	64.29		
4	TRA01A50 - Transportul rutier al materialelor,semifabricatelor cu autobasculanta pe dist.= 50 km. \$	tona	64.29		
			material:		
			manopera:		
			utilaj:		
			transport:		
4.1	8888988 - Transportul rutier al materialelor,semifabricatelor cu autobasculanta pe	tona	64.29		
5	TRA05A02 - Transport rutier materiale,semifabricate cu autovehic.speciale(cisterna,beton.etc)pe dist.de 2 km.\$	tona	2.25		
			material:		
			manopera:		
			utilaj:		
			transport:		

SECTIUNEA TEHNICA				SECTIUNEA FINANCIARA	
Nr.	Capitol de lucrari	U.M.	Cantitatea	Pretul unitar (fara TVA) - Lei -	TOTALUL (fara TVA) - Lei -
0	1	2	3	4	5 = 3 x 4
5.1	30227 - Transport rutier materiale,semifabricate cu autovehic.speciale(cisterna,beton.etc)pe dist.de 2	tona	2.25		

TOTAL 1 (Cheltuieli directe)

Greutate Materiale (tone)	Ore Manopera	Material	Manopera	Utilaj	Transport	TOTAL

Recapitulatie	Valoare	Material	Manopera	Utilaj	Transport	TOTAL

Alte cheltuieli directe						
Contribuția asiguratorie pentru muncă						
T2 = T1 + Alte cheltuieli directe						

Cheltuieli indirecte						
Cheltuieli indirecte						
T3 = T2 + Cheltuieli indirecte						

Beneficiu						
Profit						
T4 = T3 + Beneficiu						

TOTAL GENERAL (fara TVA)	
TVA (19.00%)	
TOTAL GENERAL (inclusiv TVA)	

Director

Sef proiect

Ofertant



Beneficiar: comuna Murgasi , jud. Dolj
 Executant:
 Proiectant:
 Obiectivul: Modernizare infrastructura rutiera comuna Murgasi, judetul Dolj
 Obiectul: 5 STRADA BISERICII MURGASI
 Stadiul fizic: 2.4 Strat de uzura din BAPC 16-4 cm grosime



Formular F3 Lista cu cantitati de lucrari pe categorii de lucrari

SECTIUNEA TEHNICA				SECTIUNEA FINANCIARA	
Nr.	Capitol de lucrari	U.M.	Cantitatea	Pretul unitar (fara TVA) - Lei -	TOTALUL (fara TVA) - Lei -
0	1	2	3	4	5 = 3 x 4
1	DB01A1 - Curatirea mecanica in vederea aplicarii imbracamintilor sau tratamentelor bituminoase a straturilor suport alcatuite din : suprafete bituminoase din beton cimentat sau pavaje din piatra bitumate, executata cu peria mecanica;	mp	413.00		
			material:		
			manopera:		
			utilaj:		
			transport:		
1.1	6202806 - Apa industrială in cisterne pentru lucrari de drumuri si terasamente	mc	1.24		
1.2	4026 - Perie mec pt curatat fundatii drumuri 6 cp	ora	0.12		
1.3	5603 - Autocisterna cu dispozitiv de stropire cu M.a.J. pentru cantitati de 5-8 tone	ora	0.12		
2	DB02D1 - Amorsarea suprafetelor straturilor de baza sau a imbracamintilor existente in vvederea aplicarii unui strat de uzura din mixtura asfaltica, executata cu: emulsie cationica cu rupere rapida	100 mp	4.13		
			material:		
			manopera:		
			utilaj:		
			transport:		
2.1	2600323 - Emulsie de bitum cationica cu rupere rapida S8877	kg	187.92		
3	DB16H1 - Imbracaminte de beton asfaltic cu agregate marunte executata la cald, in grosime de : 4,0 CM cu asternere mecanica	mp	413.00		
			material:		
			manopera:		
			utilaj:		
			transport:		
3.0	20060395 - BETON ASFALTIC cu pietris concasat tip BAPC 16	t	38.82		
4	TRA01A50 - Transportul rutier al materialelor,semifabricatelor cu autobasculanta pe dist.= 50 km. \$	tona	38.82		
			material:		
			manopera:		
			utilaj:		
			transport:		
4.1	8888988 - Transportul rutier al materialelor,semifabricatelor cu autobasculanta pe	tona	38.82		
5	TRA05A02 - Transport rutier materiale,semifabricate cu autovehic.speciale(cisterna,beton.etc)pe dist.de 2 km.\$	tona	1.42		
			material:		
			manopera:		
			utilaj:		
			transport:		

SECTIUNEA TEHNICA				SECTIUNEA FINANCIARA	
Nr.	Capitol de lucrari	U.M.	Cantitatea	Pretul unitar (fara TVA) - Lei -	TOTALUL (fara TVA) - Lei -
0	1	2	3	4	5 = 3 x 4
5.1	30227 - Transport rutier materiale, semifabricate cu autovehic. speciale (cisterna, beton, etc) pe dist. de 2	tona	1.42		

TOTAL 1 (Cheltuieli directe)

Greutate Materiale (tone)	Ore Manopera	Material	Manopera	Utilaj	Transport	TOTAL

Recapitulatie	Valoare	Material	Manopera	Utilaj	Transport	TOTAL

Alte cheltuieli directe

Contribuția asiguratorie pentru muncă						
---------------------------------------	--	--	--	--	--	--

T2 = T1 + Alte cheltuieli directe

Cheltuieli indirecte						
Cheltuieli indirecte						
T3 = T2 + Cheltuieli indirecte						

Beneficiu

Profit						
--------	--	--	--	--	--	--

T4 = T3 + Beneficiu

TOTAL GENERAL (fara TVA)	
TVA (19.00%)	
TOTAL GENERAL (inclusiv TVA)	

Director

Sef proiect

Ofertant



Beneficiar: comuna Murgasi , jud. Dolj
 Executant:
 Proiectant:
 Obiectivul: Modernizare infrastructura rutiera comuna Murgasi, judetul Dolj
 Obiectul: 5 STRADA BISERICII MURGASI
 Stadiul fizic: 3.1 Marcaje rutiere longitudinale



Formular F3 Lista cu cantitati de lucrari pe categorii de lucrari

SECTIUNEA TEHNICA				SECTIUNEA FINANCIARA	
Nr.	Capitol de lucrari	U.M.	Cantitatea	Pretul unitar (fara TVA) - Lei -	TOTALUL (fara TVA) - Lei -
0	1	2	3	4	5 = 3 x 4
1	DF16A1 - Marcaje rutiere longitudinale, simple sau duble, cu intreruperi sau continue, executate mecanizat cu vopsea de email cu microbule de sticla;	km	0.28		
			material:		
			manopera:		
			utilaj:		
	transport:				
1.1	2600206 - Bitum pt drumuri tip D 80/120 stas 754	kg	0.34		
1.2	6108804 - Email alb II E.109-5 ni 1707-61	kg	14.12		
1.3	6109418 - Diluant ptr produse de marcare D009-3 ni 1708-61 a9	kg	0.69		
1.4	6200676 - White spirit rafinat tip a stas 44	kg	0.22		
1.5	7329912 - Microbule sticla semnaliz.orient albe D = 02-05 MM.	kg	4.73		
1.6	2200525 - Nisip de rau si lacuri sortat si nespalat, 0.0-7.00 mm	mc	0.00		
1.7	10200 - Asfaltator	ora	0.93		
1.8	4062 - Masina de trasat benzi de circulatie motor ardere interna 40-45cp	ora	0.08		

TOTAL 1 (Cheltuieli directe)

Greutate Materiale (tone)	Ore Manopera	Material	Manopera	Utilaj	Transport	TOTAL

Recapitulatie	Valoare	Material	Manopera	Utilaj	Transport	TOTAL

Alte cheltuieli directe						
Contribuția asiguratorie pentru muncă						
T2 = T1 + Alte cheltuieli directe						

Cheltuieli indirecte						
Cheltuieli indirecte						
T3 = T2 + Cheltuieli indirecte						

Beneficiu						
Profit						
T4 = T3 + Beneficiu						

TOTAL GENERAL (fara TVA)	
TVA (19.00%)	
TOTAL GENERAL (inclusiv TVA)	

Director

Sef proiect

Ofertant



Beneficiar: comuna Murgasi , jud. Dolj
 Executant:
 Proiectant:
 Obiectivul: Modernizare infrastructura rutiera comuna Murgasi, judetul Dolj
 Obiectul: 5 STRADA BISERICII MURGASI
 Stadiul fizic: 3.2 Indicatoare de circulatie



Formular F3

Lista cu cantitati de lucrari pe categorii de lucrari

SECTIUNEA TEHNICA				SECTIUNEA FINANCIARA	
Nr.	Capitol de lucrari	U.M.	Cantitatea	Pretul unitar (fara TVA) - Lei -	TOTALUL (fara TVA) - Lei -
0	1	2	3	4	5 = 3 x 4
1	DF18A1 - Plantarea stilpilor pentru indicatoare de circulatie rutiera din : metal, confectionati industrial ;	buc	1.00		
			material:		
			manopera:		
			utilaj:		
			transport:		
1.1	10173 - Beton preparate	mc	0.10		
1.1.1	2100945 - Beton de ciment B 150 stas 3622	mc	0.10		
1.2	10826 - Stilp metalici ptr indicatoare	buc	1.00		
1.2.1	6301793 - Stilp metalic confectionat industrial	buc	1.00		
1.3	11000 - Betonist	ora	0.33		
1.4	20650 - Muncitor de deservire pentru montajul in constructii	ora	0.84		
2	DF19A1 - Montarea indicatoarelor pentru circulatia rutiera din tabla de otel sau aluminiu pe : un stalp gata plantat;	buc	1.00		
			material:		
			manopera:		
			utilaj:		
			transport:		
2.1	10821 - Indicatoare de circulatie	buc	1.00		
2.1.1	7101619 - Indicator circul.tbl.OL+fol.R.octogon H = 700MM F35 S1848	buc	1.00		
2.1	7100017 - Indicator circul.tbl.OL+fol.R. triunghi L = 700MM F 1 S1848	buc	0.00		
2.1	7100029 - Indicator circul.tbl.OL+fol.R. triunghi L = 700MM F 2 S1848	buc	0.00		
2.2	5800376 - Surub cap hexagonal precis M 6 X 25 GR. 5.8 S4272	buc	4.00		
2.3	5817446 - Surub cap hexagonal semiprecis M 8X 30 GR. 5.8 S 6220	buc	2.00		
2.4	5840405 - Piulita hexagonala grosolana 6 GR. 5 S 922	buc	4.00		
2.5	5840766 - Piulita hexagonala grosolana B m 8 GR. 5 S 922	buc	2.00		
2.6	5882142 - Saiba prec.plata pt.met a m 8 OL34 S 5200	kg	0.02		
2.7	5882489 - Saiba prec.plata pentru met B m 6 OL 34 S 5200	kg	0.04		
2.8	13430 - Dulgher poduri	ora	0.22		
2.9	20640 - Muncitor deservire constructii masini	ora	0.22		

SECTIUNEA TEHNICA				SECTIUNEA FINANCIARA	
Nr.	Capitol de lucrari	U.M.	Cantitatea	Pretul unitar (fara TVA) - Lei -	TOTALUL (fara TVA) - Lei -
0	1	2	3	4	5 = 3 x 4
3	TRA06A20 - Transportul rutier al betonului-mortarului cu autobetoniera de 5,5MC dist. =20km \$	tona	0.24		
			material:		
			manopera:		
			utilaj:		
			transport:		
3.1	30295 - Transportul rutier al betonului-mortarului cu autobetoniera de 5,5MC dist. = 20km	tona	0.24		
4	TRA02A50 - Transportul rutier al materialelor,semifabricatelor cu autocamionul pe dist.= 50 km.	tona	0.03		
			material:		
			manopera:		
			utilaj:		
			transport:		
4.1	8889039 - Transportul rutier al materialelor,semifabricatelor cu autocamionul pe dist.=	tona	0.03		

TOTAL 1 (Cheltuieli directe)

Greutate Materiale (tone)	Ore Manopera	Material	Manopera	Utilaj	Transport	TOTAL

Recapitulatie	Valoare	Material	Manopera	Utilaj	Transport	TOTAL

Alte cheltuieli directe						
Contribuția asiguratorie pentru muncă						
T2 = T1 + Alte cheltuieli directe						

Cheltuieli indirecte						
Cheltuieli indirecte						
T3 = T2 + Cheltuieli indirecte						

Beneficiu						
Profit						
T4 = T3 + Beneficiu						

TOTAL GENERAL (fara TVA)	
TVA (19.00%)	
TOTAL GENERAL (inclusiv TVA)	

Director

Sef proiect

Ofertant



Beneficiar: comuna Murgasi , jud. Dolj

Executant:

Proiectant:

Obiectivul: Modernizare infrastructura rutiera comuna Murgasi, judetul Dolj



Formular C6

Lista cuprinzand consumurile de resurse materiale

Nr.	Denumirea resursei materiale	U.M.	Consumul cuprins in oferta	Pretul unitar (fara TVA) - Lei -	Valoarea (fara TVA) - Lei -	Furnizorul	Greutatea (tone)
0	1	2	3	4	5 = 3 X 4	6	7
1	11850115.00 - Plasa sudate STM O8 10X10 cm 600x200 cm	buc.	3.00			Depozit	0.27
2	2000092 - Otel beton profil neted OB37 stas 438 D= 8MM	kg	16.93			Depozit	0.02
3	20020391 - BETON ASFALTIC DESCHIS pietris concasat tip BADPC 22,4	t	327.52			Depozit	327.52
4	2005913 - Plasa stnb o8 , 10x10 cm , 600 x200 cm	buc.	1.00			Depozit	0.05
5	20060395 - BETON ASFALTIC cu pietris concasat tip BAPC 16	t	197.78			Depozit	197.78
6	2100945 - Beton de ciment B 150 stas 3622	mc	0.60			Depozit	1.48
7	2100995 - Beton de ciment B 400-BC30 stas 3622	mc	76.53			Depozit	202.81
8	2101183 - Mortar de zidarie M 100 S 1030	mc	0.20			Depozit	0.48
9	2101995 - Beton C 30/37	mc	9.76			Depozit	25.86
10	2200379 - Balast sortat spalat de mal 0-70 MM	mc	13.92			Depozit	23.66
11	2200393 - Balast sortat nespalat de rau 0-63 mm	mc	551.67			Depozit	937.84
12	2200446 - Bolovani de riu pentru drumuri, cai ferate 150-300 MM	mc	0.17			Depozit	0.27
13	2200525 - Nisip de rau si lacuri sortat si nespalat, 0.0-7.00 mm	mc	1.20			Depozit	1.62
14	2201658 - Piatra sparta pentru drumuri R.magmatice 15-25 MM.	mc	64.07			Depozit	96.10
15	2201672 - Piatra sparta pt drumuri R.magmatice 40-63 MM.	mc	384.72			Depozit	577.07
16	2600206 - Bitum pt drumuri tip D 80/120 stas 754	kg	1.74			Depozit	0.00
17	2600323 - Emulsie de bitum cationica cu rupere rapida S8877	kg	1,914.64			Depozit	2.11
18	2901167 - Manele D=7-11CM L=2-6M rasinoase S.1040	mc	0.11			Depozit	0.07
19	2903969 - Scindura rasin lunga tiv cls D GR = 18MM L = 6,00M s 942	mc	0.03			Depozit	0.01
20	2908737 - Grinda rasin.cu 2 fete plane gros = 10/12-35/35 L = 4-6M	mc	0.08			Depozit	0.04
21	2928335 - Panou de cofraj tip P fag G 8 MM pentru pereti	mp	3.59			Depozit	0.08
22	2928347 - Panou de cofraj tip P fag G 15MM pentru pereti	mp	0.31			Depozit	0.01
23	3803116 - Sirma moale obisnuita D= 1 OL32 S 889	kg	8.08			Depozit	0.01

Nr.	Denumirea resursei materiale	U.M.	Consumul cuprins in oferta	Pretul unitar (fara TVA) - Lei -	Valoarea (fara TVA) - Lei -	Furnizorul	Greutatea (tone)
0	1	2	3	4	5 = 3 X 4	6	7
24	3803269 - Sarma moale obisnuita D = 3 MM, OL 32 S 889	kg	4.25			Depozit	0.00
25	5800376 - Surub cap hexagonal precis M 6 X 25 GR. 5.8 S4272	buc	24.00			Depozit	0.00
26	5817446 - Surub cap hexagonal semiprecis M 8X 30 GR. 5.8 S 6220	buc	12.00			Depozit	0.00
27	5840405 - Piulita hexagonala grosolana 6 GR. 5 S 922	buc	24.00			Depozit	0.00
28	5840766 - Piulita hexagonala grosolana B m 8 GR. 5 S 922	buc	12.00			Depozit	0.00
29	5882142 - Saiba prec.plata pt.met a m 8 OL34 S 5200	kg	0.12			Depozit	0.00
30	5882489 - Saiba prec.plata pentru met B m 6 OL 34 S 5200	kg	0.24			Depozit	0.00
31	5886954 - Cuie cu cap conic tip a1 3 X 80 OL34 S 2111	kg	0.07			Depozit	0.00
32	600888162 - Teava corugat adin polietilena de inalta densitate clasa de rigiditate SN8, Diam = 600 mm , L = 5.00 m	buc	1.00			Depozit	0.01
33	6108804 - Email alb II E.109-5 ni 1707-61	kg	73.12			Depozit	0.08
34	6109418 - Diluant ptr produse de marcare D009-3 ni 1708-61 a9	kg	3.58			Depozit	0.00
35	6200676 - White spirit rafinat tip a stas 44	kg	1.16			Depozit	0.00
36	6202806 - Apa industriala in cisterne pentru lucrari de drumuri si terasamente	mc	193.53			Depozit	193.53
37	6301793 - Stilp metalic confectionat industrial	buc	6.00			Depozit	0.09
38	6311528 - Scoaba otel pentru constructii din lemn, latime= 65-90MM, L.200-300 MM	kg	2.90			Depozit	0.00
39	7100017 - Indicator circul.tbl.OL+fol.R. triunghi L =	buc	0.00			Depozit	0.00
40	7100029 - Indicator circul.tbl.OL+fol.R. triunghi L =	buc	0.00			Depozit	0.00
41	7101619 - Indicator circul.tbl.OL+fol.R.octogon H =	buc	6.00			Depozit	0.03
42	7315789 - Decofrol	kg	9.76			Depozit	0.01
43	7329912 - Microbile sticla semnaliz.orizontal albe D = 02-05 MM.	kg	24.50			Depozit	0.02
44	C64331 - Dala curenta prefabricata din beton armat 49x30x15	buc	52.36			Depozit	0.89
TOTAL Materiale						Greutate	2,589.83

Director

Sef proiect

Ofertant



Beneficiar: comuna Murgasi , jud. Dolj

Executant:

Proiectant:

Obiectivul: Modernizare infrastructura rutiera comuna Murgasi, judetul Dolj



Formular C7

Lista cuprinzand consumurile cu mana de lucru

Nr.	Denumirea meseriei	Consumul cu manopera - Om/ore -	Tarif mediu - Lei/ora -	Valoarea (fara TVA) - Lei -	Procent romani
0	1	2	3	4 = 2 X 3	5
1	10200 - Asfaltator	4.81			
2	11000 - Betonist	420.05			
3	13410 - Dulgher constructii	61.86			
4	13430 - Dulgher poduri	1.32			
	15000 - Fierar beton	12.42			
6	15130 - Finisor de terasamente	146.41			
7	19770 - Montator prefabricate beton	15.60			
8	20640 - Muncitor deservire constructii masini	1.32			
9	20650 - Muncitor de deservire pentru montajul in constructii	517.93			
10	20900 - Muncitor incarcare-descarcare materiale	86.72			
11	24100 - Pavator	345.05			
12	24400 - Pietrar	29.35			
13	26100 - Sapator	169.88			
14	31000 - Zidar	14.54			
	Ore Manopera	1,827.25	TOTAL		

Director

Sef proiect

Ofertant



Beneficiar: comuna Murgasi , jud. Dolj
 Executant:
 Proiectant:
 Obiectivul: Modernizare infrastructura rutiera comuna Murgasi, judetul Dolj



Formular C8

Lista cuprinzand consumurile de ore de functionare a utilajelor de constructii

Nr.	Denumirea utilajului de constructii	Ore de functionare	Tariful unitar (fara TVA) - Lei/ora -	Valoarea (fara TVA) - Lei -
0	1	2	3	4 = 2 X 3
1	3336 - Pompa hidraulica de beton cu 100M conducta,pina la 40 MC/H	0.99		
2	3521 - Excavator pe pneuri motor termic(buldoexcavator)0,21-0,39MC	4.82		
3	3546 - Autogreder pina la 175cp	33.45		
4	3554 - Buldozer pe senile 81-180 cp	0.46		
5	3720 - Vibrator universal cu motor termic 2,9-4cp	6.65		
6	4004 - Compactor autoprop.cu rulour.(valturi) pina la 12tf	26.04		
7	4005 - Compactor static autoprop.cu rulouri(valturi),R8-14;de 14tf	145.81		
8	4026 - Perie mec pt curatat fundatii drumuri 6 cp	1.89		
9	4062 - Masina de trasat benzi de circulatie motor ardere interna 40-45cp	0.42		
10	4201 - Masina automata de taiat si indret.ot.bet.act.el. D=3-20MM 5-10	0.10		
11	4203 - Stanta electrica de taiat otel-beton,diampina la 40 MM	0.12		
12	4205 - Masina de fasonat otel-beton D=pina la 40MM 2,2KW	0.36		
13	5603 - Autocisterna cu dispozitiv de stropire cu M.a.J. pentru cantitati de 5-8 tone	16.10		
14	6609 - Troliu electric 3,1-5tf	0.05		
TOTAL Utilaje				

Director

Sef proiect

Ofertant



Beneficiar: comuna Murgasi , jud. Dolj

Executant:

Proiectant:

Obiectivul: Modernizare infrastructura rutiera comuna Murgasi, judetul Dolj



Formular C9

Lista cuprinzand consumurile privind transporturile

Nr.	Tipul de transport	Tone transportate	Km parcursi	Ore de functionare	Tariful unitar - Lei\ (Tone*Km	Valoarea - Lei -
0	1	2	3	4	5	6 = 2 X 3 X 5
1	30227 - Transport rutier materiale,semifabricate cu autovehic.speciale(cisterna,beton.etc)pe	89.79	2.00	0.05		
2	30285 - Transportul rutier al betonului-mortarului cu autobetoniera de 5,5MC dist. = 10km	11.02	10.00	0.25		
3	30295 - Transportul rutier al betonului-mortarului cu autobetoniera de 5,5MC dist. = 20km	147.11	20.00	0.50		
4	30325 - Transportul rutier al betonului-mortarului cu autobetoniera de 5,5 MC dist. = 50 km	99.06	50.00	1.25		
5	8888892 - Transportul rutier al materialelor,semifabricatelor cu autobasculanta pe dist.= 2 km.	132.52	2.00	0.05		
6	8888893 - Transportul rutier al pamintului sau molozului cu autobasculanta dist.= 2 km	18.77	2.00	0.05		
7	8888899 - Transportul rutier al pamintului sau molozului cu autobasculanta dist.= 5 km	413.89	5.00	0.12		
8	8888908 - Transportul rutier al materialelor,semifabricatelor cu autobasculanta pe dist.= 10 km.	1.26	10.00	0.25		
9	8888916 - Transportul rutier al materialelor,semifabricatelor cu autobasculanta pe dist.= 14 km.	21.79	14.00	0.35		
0	8888958 - Transportul rutier al materialelor,semifabricatelor cu autobasculanta pe dist.= 35 km.	18.70	35.00	0.88		
11	8888988 - Transportul rutier al materialelor,semifabricatelor cu autobasculanta pe dist.= 50 km.	2,060.80	50.00	1.25		
12	8888991 - Transportul rutier al materialelor,semifabricatelor cu autocamionul pe dist.= 2 km.	18.60	2.00	0.05		
13	8888999 - Transportul rutier al materialelor,semifabricatelor cu autocamionul pe dist.= 10 km.	0.27	10.00	0.25		
14	8889039 - Transportul rutier al materialelor,semifabricatelor cu autocamionul pe dist.= 50 km.	0.17	50.00	1.25		
TOTAL Transport						

Nr.	Tipul de transport	Tone transportate	Km parcursi	Ore de functionare	Tariful unitar - Lei\{(Tone*Km	Valoarea - Lei -
0	1	2	3	4	5	6 = 2 X 3 X 5

Director

Sef proiect

Ofertant





Proiect Nr. 7/2023

Faza de proiectare:

**PROIECT TEHNIC
DE EXECUTIE**



Obiectiv de investitii:

**MODERNIZARE INFRASTRUCTURA RUTIERA COMUNA
MURGASI, JUD. DOLJ**



Partea VI

PIESE DESENATE

Proiectant:

ROAD VISION DESIGN SRL

Reg. Com.: J16/1802/2023

CUI: RO48687236

Tel: 0770735796

mail: road.vd@yahoo.com



Autoritatea contractanta:

Comuna MURGASI,

Judetul DOLJ

Tel/Fax: 0251 447507

E-mail: primaria.murgasi@gmail.com



Nr. Crt.	Denumire strada - ulita	Lungime
1.	DC 128A	145 m
2.	Strada Fanianitei	325 m
3.	Strada Bisericii Busteni	45 m
4.	Strada Bisericii Gaia-Tronson 2	70 m
5.	Strada Bisericii Murgasi	140 m
6.	TOTAL	725 m

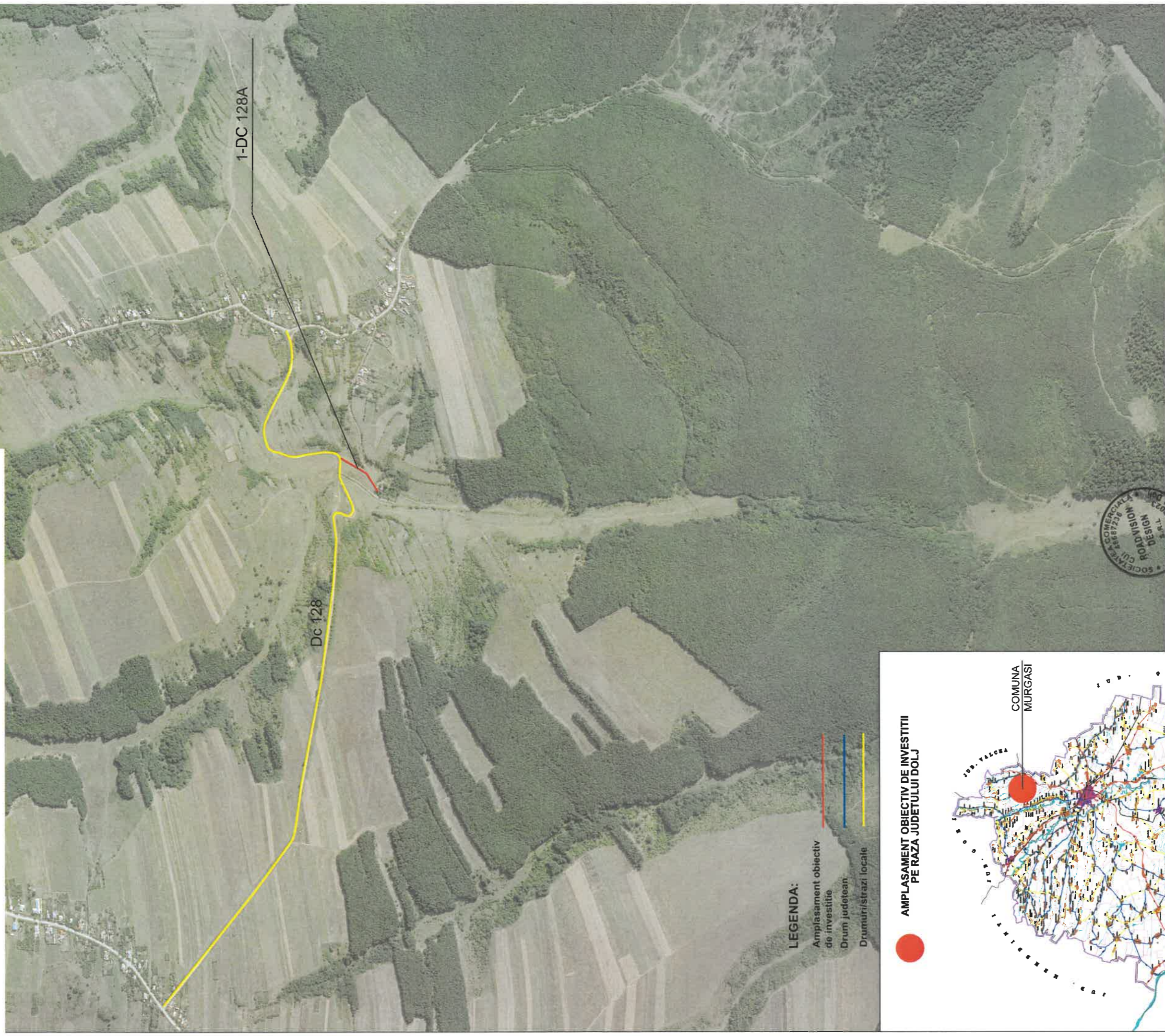

LEGENDA:

- Amplasament obiectiv de investitie
- Drum județean
- Drumuri/strazi locale

AMPLASAMENT OBIECTIV DE INVESTITII PE RAZA JUDEȚULUI DOLJ

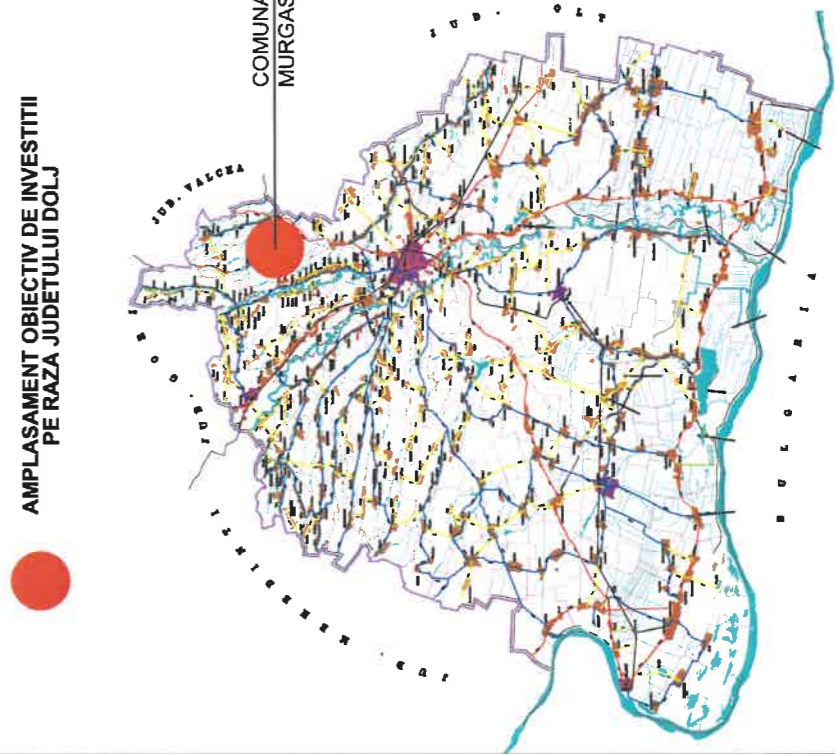

ROADVISION DESIGN SRL
 Str. G. Mihail Cerchez, Nr. 10, Bl. A8, Ap. 3, CRAIOVA, judetul DOLJ
 J16 / 1802 / 2023, CUI - RO46887236



SPECIFICATIE	NUME	SEMNATURA	Scara:
SEF PROIECT	ing. Mihai Sorin		1:10 000
PROIECTAT	ing. Mihai Sorin		
DESENAT	ing. Rotaru Cristi		
VERIFICAT	ing. Stavaru Bogdan		

Beneficiar:
Comuna Murgasi, Judetul Dolj

Titlu proiect:
**MODERNIZARE INFRASTRUCTURA RUTIERA
 COMUNA MURGASI, JUDEȚUL DOLJ**

Titlu planșa:
**PLAN DE INCADRARE IN ZONA
 SCHITA DE ANSAMBLU**

Proiect nr.
7 / 2023

Faza:
P.T.Ex.

Planșa nr.
01-SA-01

Nr. Crt.	Denumire strada - ulita	Lungime
1.	DC 128A	145 m
2.	Strada Fantanitei	325 m
3.	Strada Bisericii Busteni	45 m
4.	Strada Bisericii Gaia-Tronson 2	70 m
5.	Strada Bisericii Murgasi	140 m
6.	TOTAL	725 m

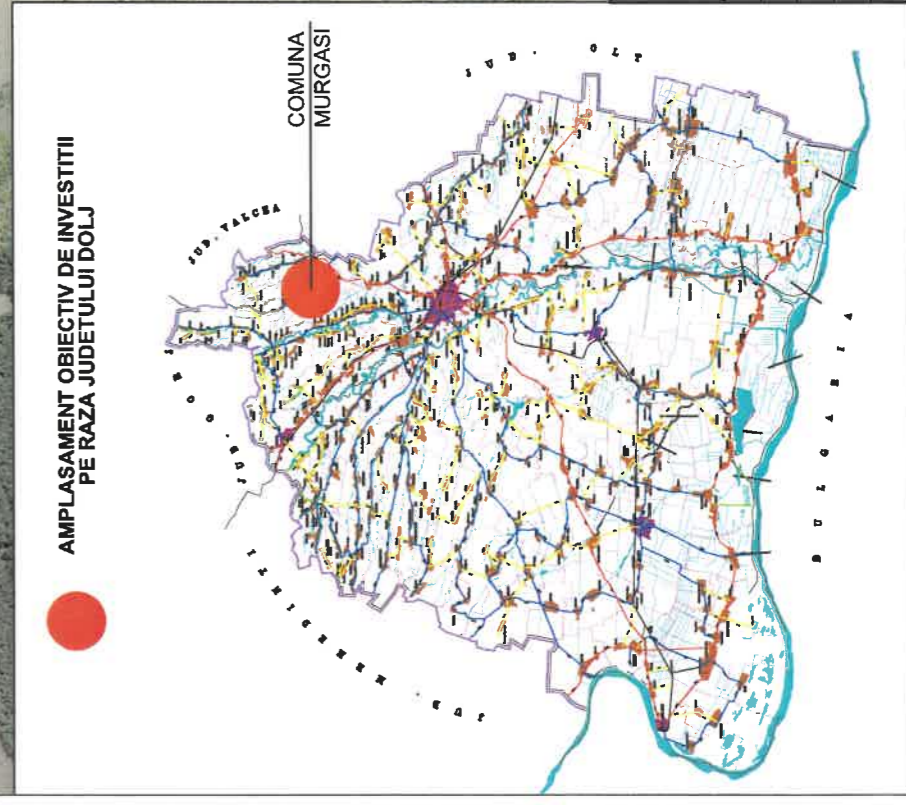
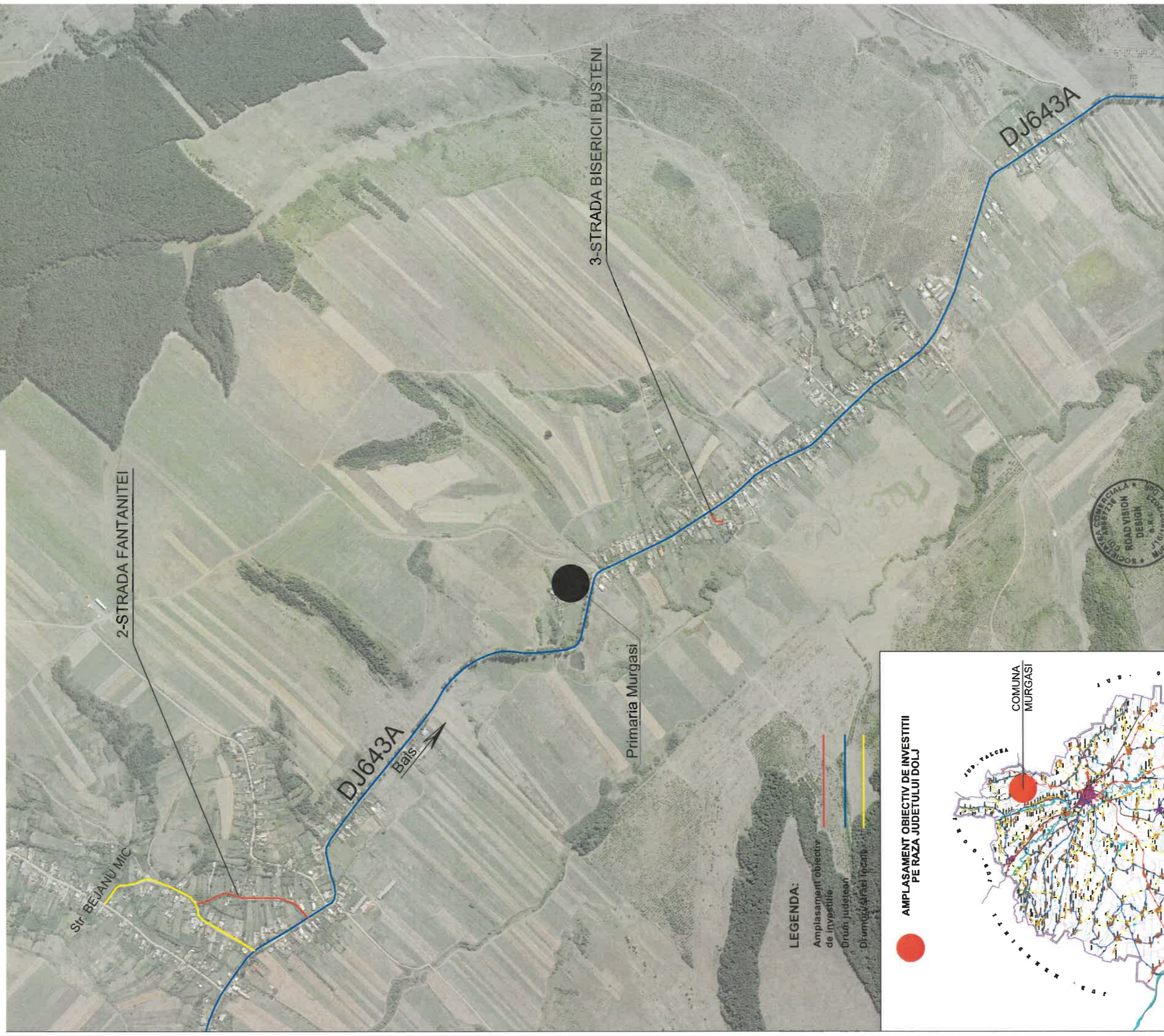

SPECIFICATIE		NUME	SEMNATURA
SEF PROIECT	ing. Mihai Sorin		
PROIECTAT	ing. Mihai Sorin		
DESENAT	ing. Rotaru Cristi		
VERIFICAT	ing. Stavaru Bogdan		

Beneficiar:	Comuna Murgasi, Judetul Dolj	Proiect nr.	7 / 2023
Titlu proiect:	MODERNIZARE INFRASTRUCTURA RUTIERA COMUNA MURGASI, JUDETEL DOLJ	Faza:	P.T.Ex.
Scara:	1:10 000	Titlu plansa:	PLAN DE INCADRARE IN ZONA SCHITA DE ANSAMBLU
Data:	2023	Plansa nr.	01-SA-02

ROAD VISION DESIGN SRL
 Str. G. Mihail Cerchez, Nr. 10, Bl. A9, Ap. 3, CRAIOVA, judetul DOLJ
 J16 / 1802 / 2023, CUI - RO46887236



Nr. Crt.	Denumire strada - ulita	Lungime
1.	DC 128A	145 m
2.	Strada Fantantei	325 m
3.	Strada Bisericii Busteni	45 m
4.	Strada Bisericii Gaia-Tronson 2	70 m
5.	Strada Bisericii Murgasi	140 m
6.	TOTAL	725 m

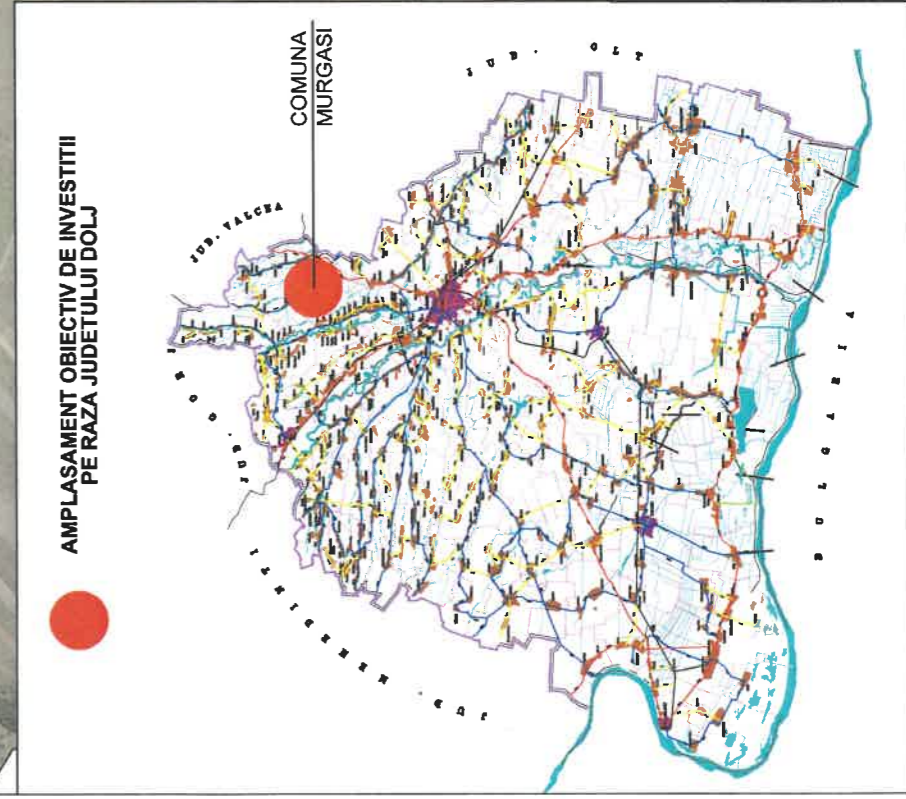
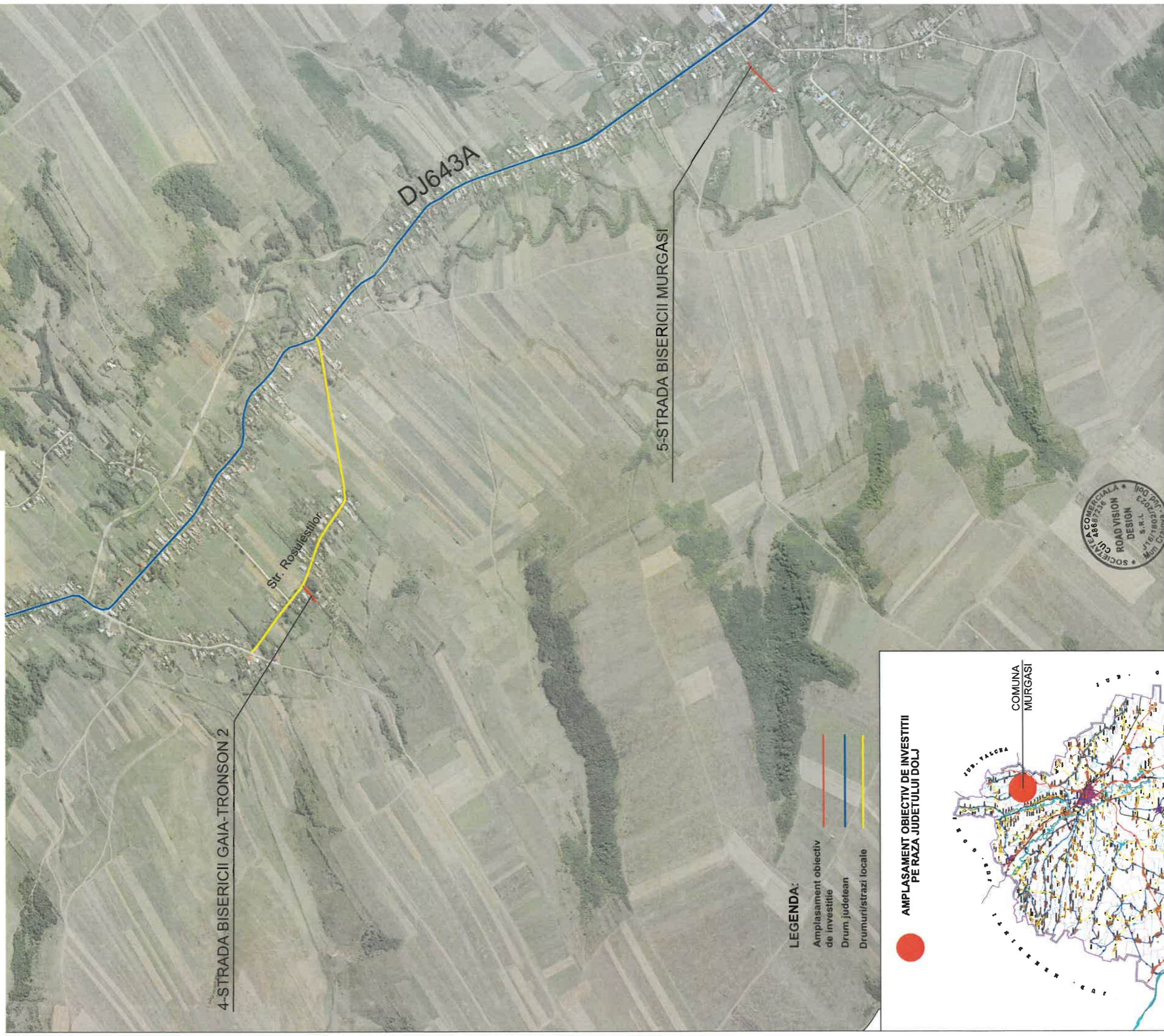

ROAD VISION DESIGN SRL Str. G. Mihail Cerchez, Nr. 10, Bl. Ap. 3, CRAIOVA, judetul DOLJ J16 / 1802 / 2023, CUI - RO48687236		Beneficiar:	Comuna Murgasi, Judetul Dolj	Proiect nr.	7 / 2023
SPECIFICATIE	NUME	SEMNATURA	Scara:	Titlu proiect:	Faza:
SEF PROIECT	ing. Mihai Sorin	<i>[Signature]</i>	1:10 000	MODERNIZARE INFRASTRUCTURA RUTIERA COMUNA MURGASI, JUDETEL DOLJ	P.T.Ex.
PROIECTAT	ing. Mihai Sorin	<i>[Signature]</i>			
DESEENAT	ing. Rotaru Cristi	<i>[Signature]</i>	Data:	PLAN DE INCADRARE IN ZONA SCHITA DE ANSAMBLU	Planșa nr.
VERIFICAT	ing. Stavaru Bogdan	<i>[Signature]</i>	2023		01-SA-03



DC 128A Curve 1	
Curba nr.	1
Raza	60.00
Lungime	16.68
Tangenta	8.40
Unghi	15°55'48"

DC 128A Curve 2	
Curba nr.	2
Raza	100.00
Lungime	49.46
Tangenta	25.24
Unghi	28°20'10"

Statie de intoarcere L= 10.00 m,
l= 2.25 m, 1xR= 5.00 m

Rigola carosabila tip podet,
L= 4.30 m - Km: 0+100.00

Rigola carosabila tip podet,
L= 4.30 m - Km: 0+005.00

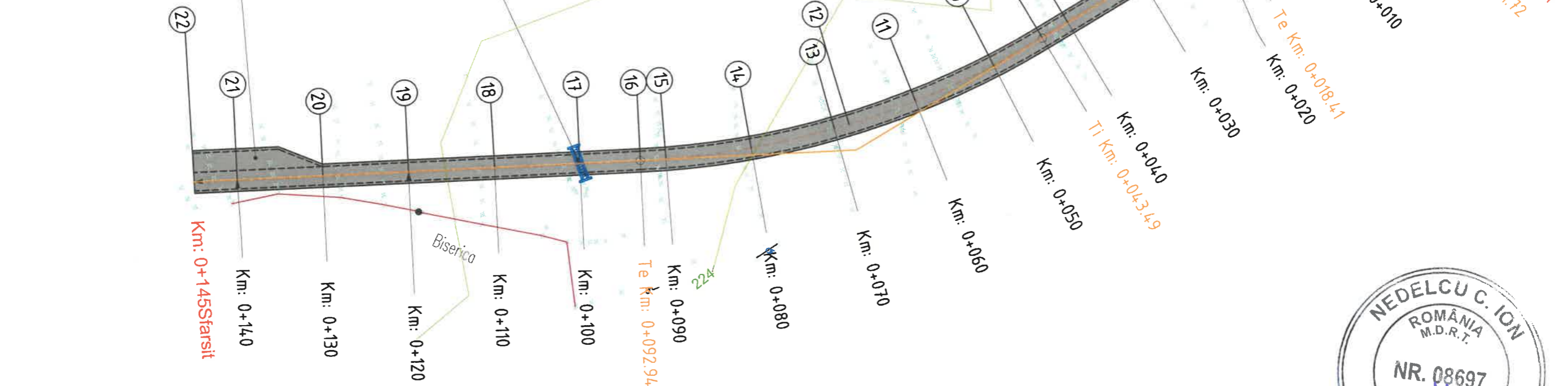

SCHEMA DE ASAMBLARE A PLANURILOR

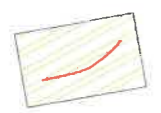

LEGENDA:

- Punct topografic
- Parte carosabila si marcaj rutier
- Ax drum proiectat
- Aerisitor instalatie gaze naturale
- Camin utilitati
- Stalp electric
- Rigola acostament
- Rigola carosabila
- Sant pereat

ROAD VISION DESIGN SRL Str. G. Mihail Kogalniceanu, Nr. 10, Bl. A9, Ap. 3, CRAIOVA, judetul DOLJ J16 / 1802 / 2023, CUI - RO48687236			Beneficiar:	Comuna Murgasi, Judetul Dolj	Proiect nr.	7 / 2023
SPECIFICATIE	NUME	SEMNATURA	Scara:	Titlu proiect:	Faza:	
SEF PROIECT	ing. Mihai Sorin		1:500	MODERNIZARE INFRASTRUCTURA RUTIERA COMUNA MURGASI, JUDETUL DOLJ	P.T.Ex.	
PROIECTAT	ing. Mihai Sorin		Data:	Titlu plansa:	Plansa nr.	
DESENAT	Ing. Rotaru Cristi		2023	PLAN DE SITUATIE DC 128A	02-PS-01-01	
VERIFICAT	Ing. Stavaru Bogdan					



BENEFICIAR:

**Comuna Murgasi,
Judetul Dolj**

DENUMIREA PROIECTULUI:

**Modernizare infrastructura rutiera
comuna Murgasi, Judetul Dolj**

PROIECTANT:



LEGENDA:
 — Linie proiect
 — Linie teren
 - - - Linie sant dreapta
 - - - Linie sant stanga

● KM =0+053.22
 mi (%) =12.50
 m (%) =11.20
 R (m) =2860
 T (m) =18.58
 B (cm) =6.03
 L (m) =37.16
 Schimbator panou

VERIFICATOR:

SEMNTURA

CERINTA: A4, B2, D

EXPERT:

SEMNTURA

CERINTA: A4, B2, D

SEF PROIECT

Ing. Mihai Sorin

Proiectat Ing. Mihai Sorin
 Desenat Ing. Rotaru Cristi

TITLU PLANSA:

**PROFIL LONGITUDINAL
DC 128A**

SCARA:

1:1000-L
 1:100-H

PROIECT: 7/2023

DATA: 2023

FAZA DE PROIECTARE P.T.Ex.

PLANSA NR. 03-PL-01-01

REVIZIA NR. 0

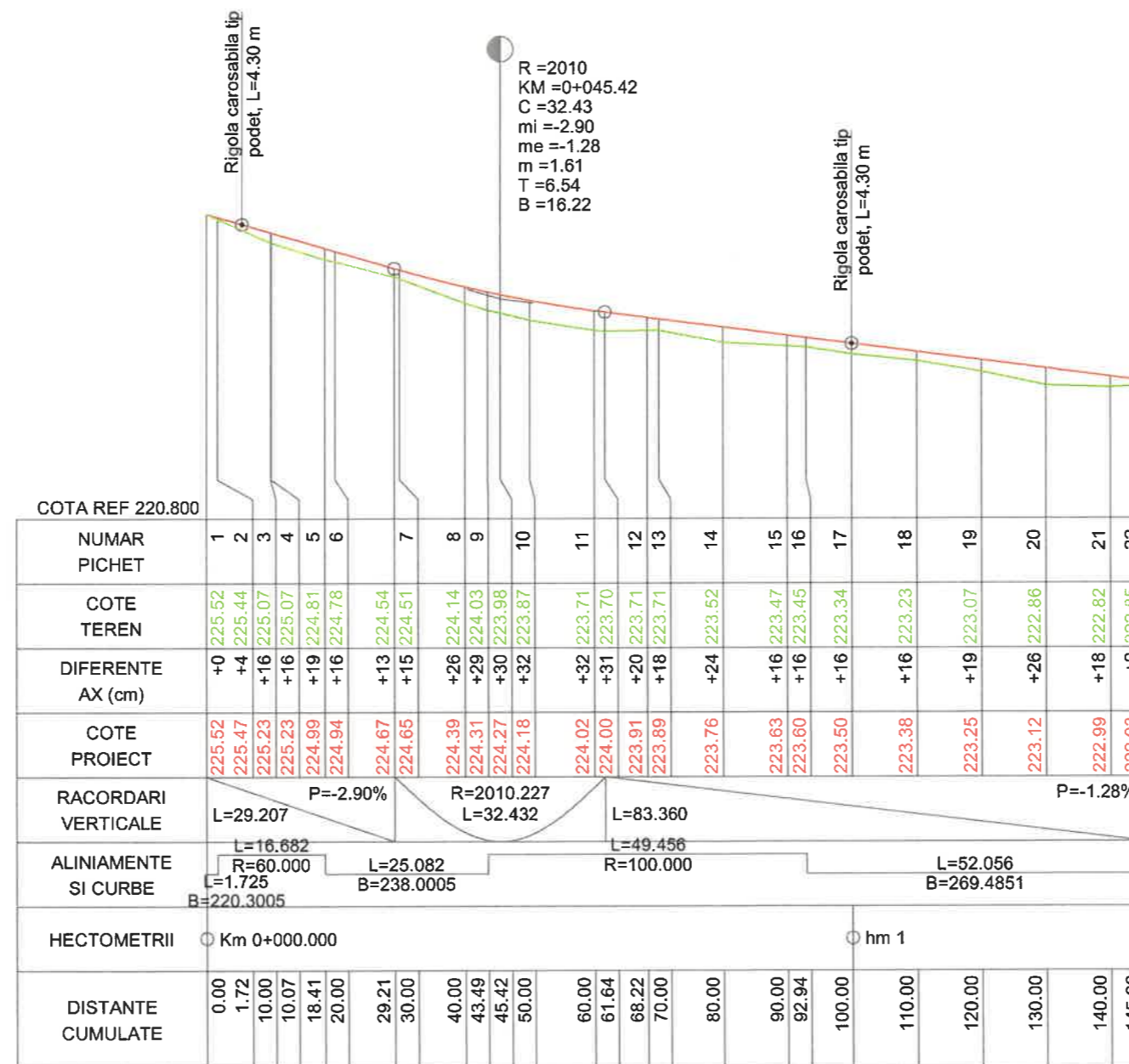

PROFIL LONGITUDINAL DC 128A DE LA 0.000 LA 145.000 SCARA : ORIZ 1 :1000 VERT 1 :100



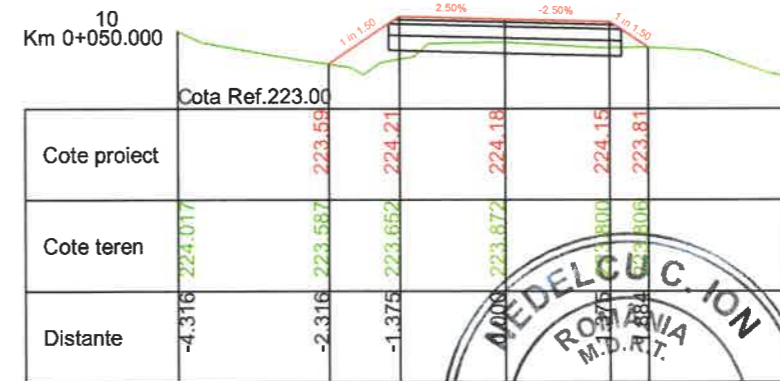
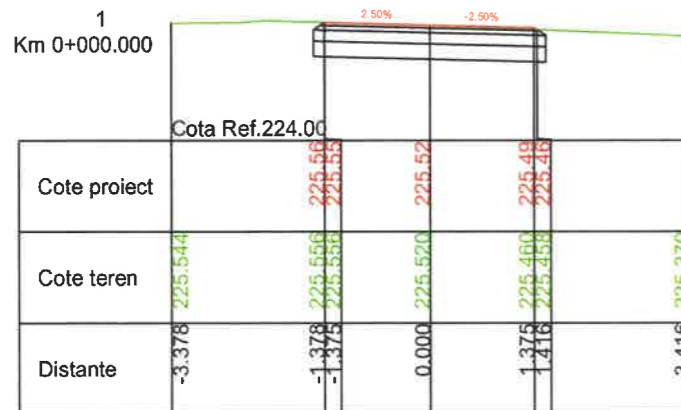
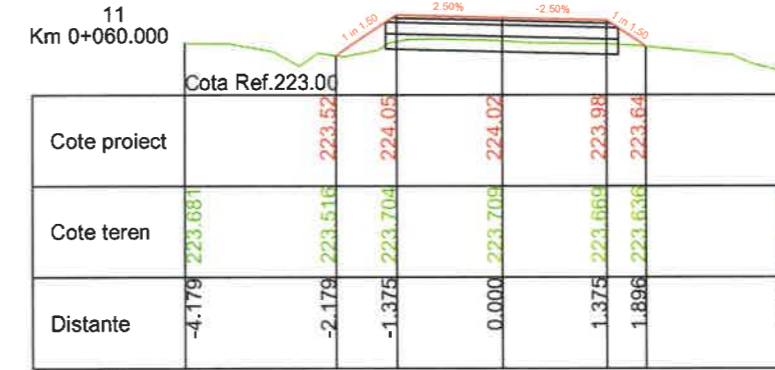
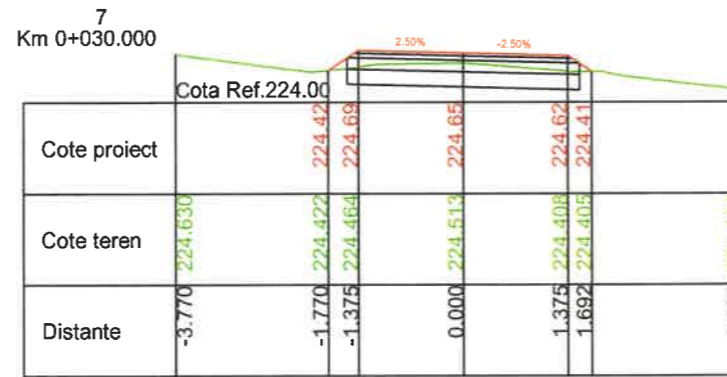
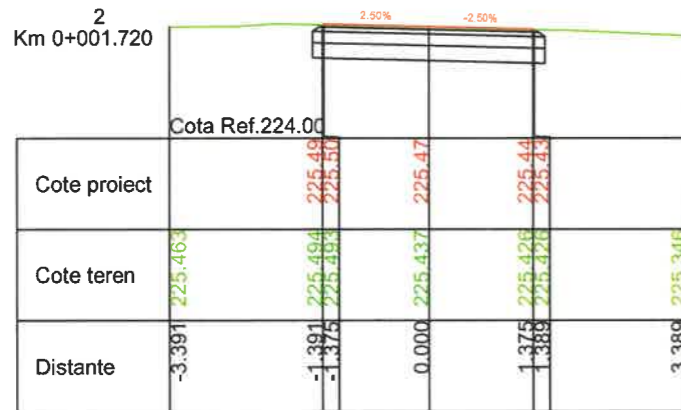
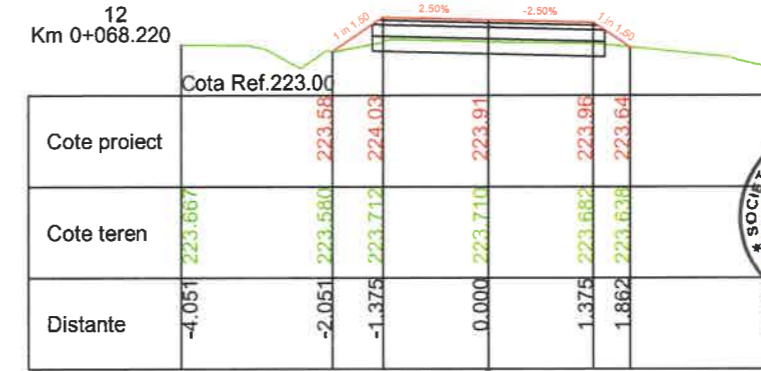
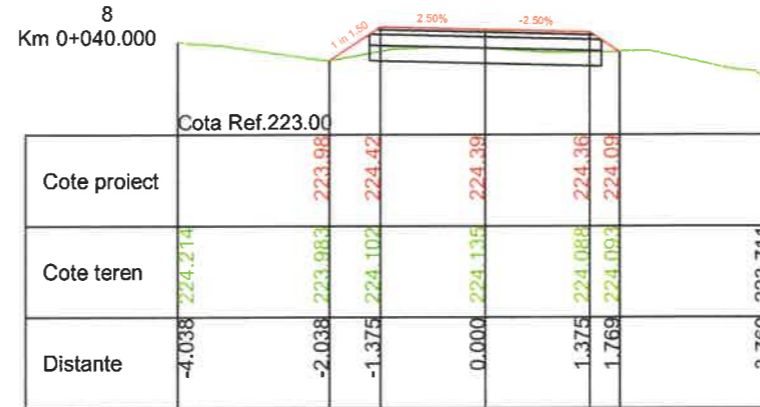
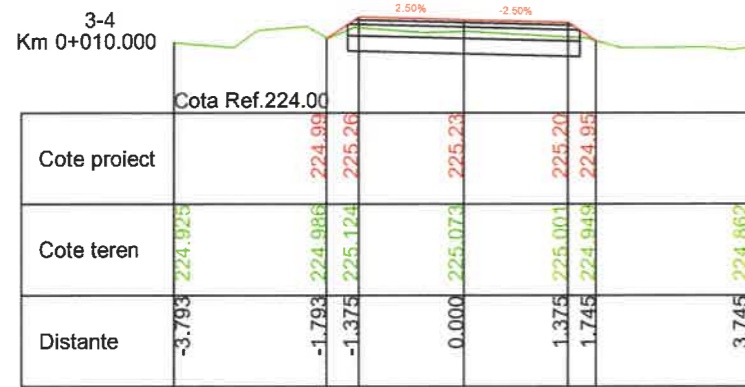
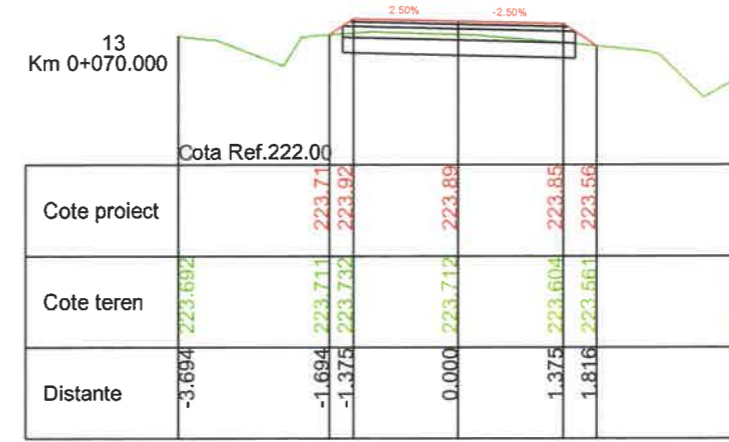
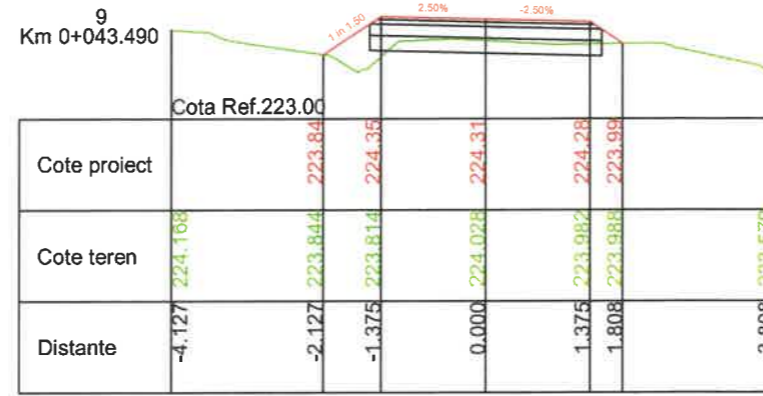
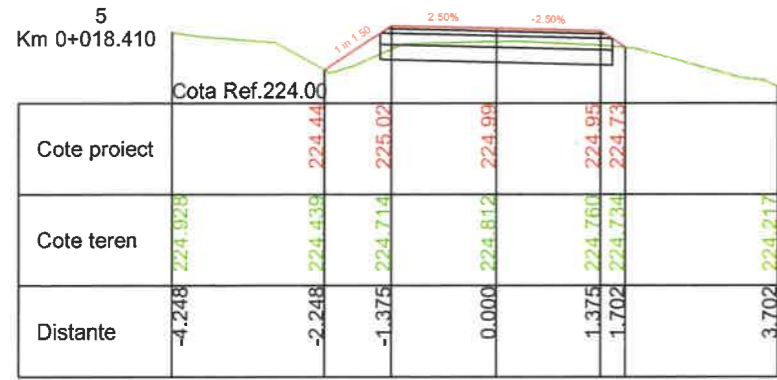

BENEFICIAR:
Comuna Murgasi, Judetul Dolj

DENUMIREA PROIECTULUI:
Modernizare infrastructura rutiera comuna Murgasi, Judetul Dolj

PROIECTANT:
ROAD VISION DESIGN SRL
Str. G. Mihail Cerchez, Nr. 10, Bl. A9, Ap. 3, CRAIOVA, Judetul DOLJ 116 / 1802 / 2023, CUI - RO48687236



LEGENDA:
— Linie proiect
— Linie teren

VERIFICATOR:
SEMNATURA
CERINTA: A4, B2, D
EXPERT:
SEMNATURA
CERINTA: A4, B2, D

SEF PROIECT
Ing. Mihai Sorin
Proiectat Ing. Mihai Sorin
Desenat Ing. Rotaru Cristi

TITLU PLANSĂ:
PROFILE TRANSVERSALE DC 128A

SCARA:
1:100
PROIECT: 7/2023
DATA: 2023
FAZA DE PROIECTARE: P.T.Ex.
PLANSĂ NR.: 04-PT-01-01
REVIZIA NR.: 0



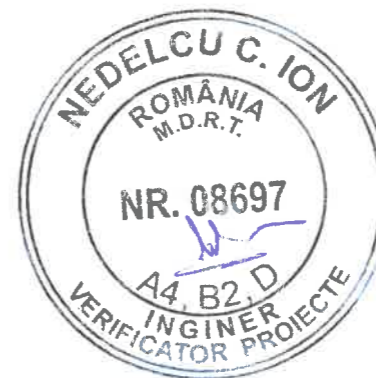

BENEFICIAR:

Comuna Murgasi,
Judetul Dolj

DENUMIREA PROIECTULUI:

Modernizare infrastructura rutiera
comuna Murgasi, Judetul Dolj

PROIECTANT:



LEGENDA:

- Linie proiect
- Linie teren

VERIFICATOR:

SEMNTURA

CERINTA: A4, B2, D

EXPERT:

SEMNTURA

CERINTA: A4, B2, D

SEF PROIECT

Ing. Mihai Sorin

Proiectat Ing. Mihai Sorin
Desenat Ing. Rotaru Cristi

TITLU PLANSA:

PROFILE TRANSVERSALE
DC 128A

SCARA:

1:100

PROIECT: 7/2023

DATA: 2023

FAZA DE PROIECTARE P.T.Ex.

PLANSA NR. 04-PT-01-02

REVIZIA NR. 0

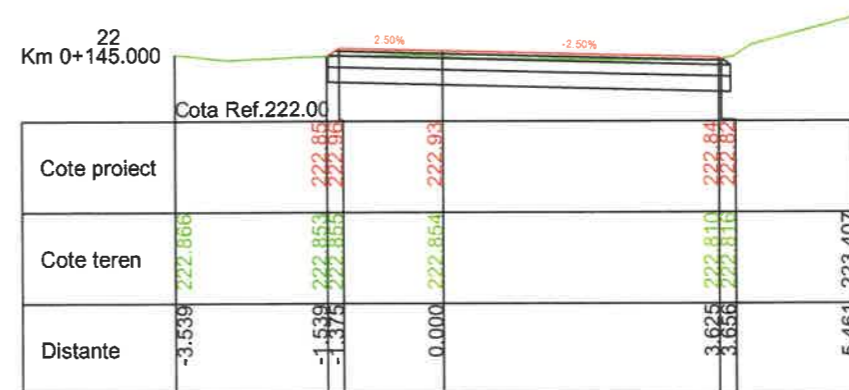
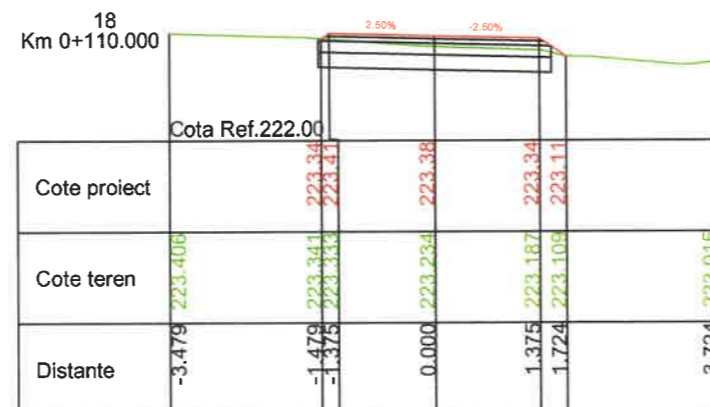
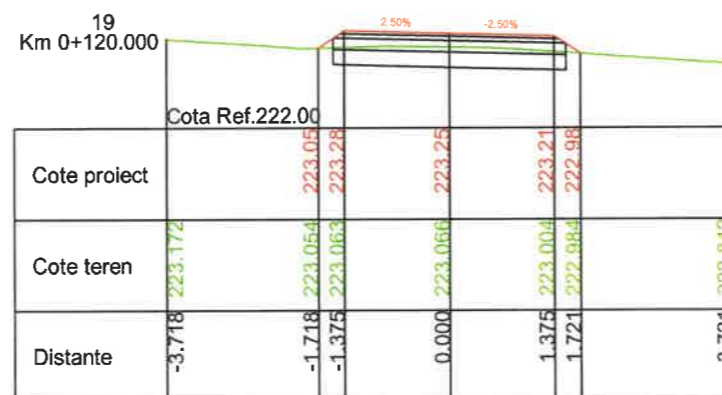
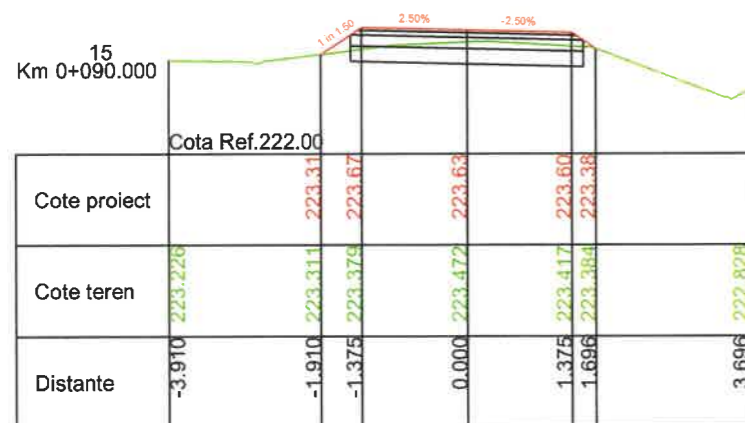
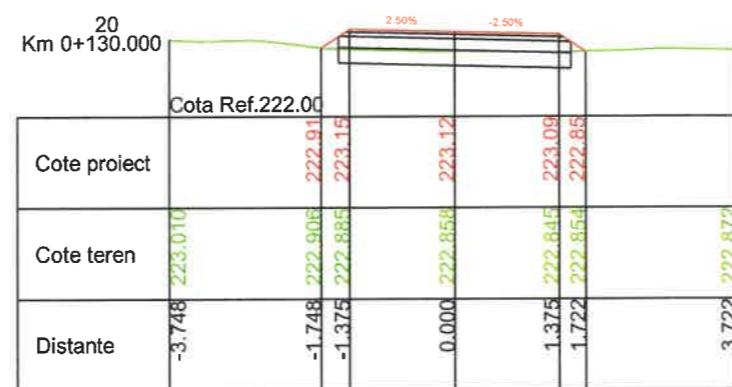
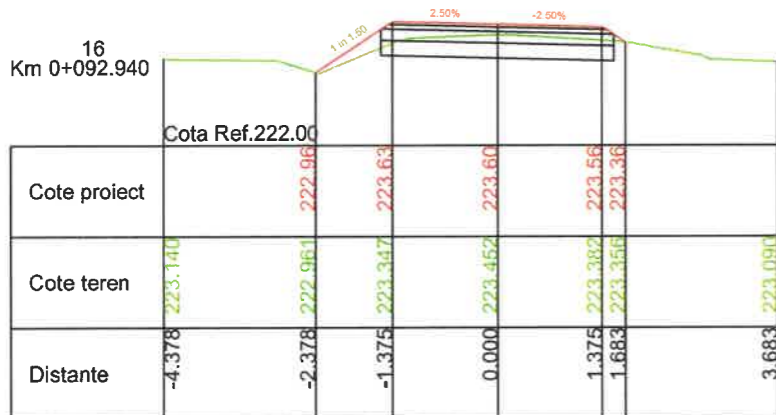
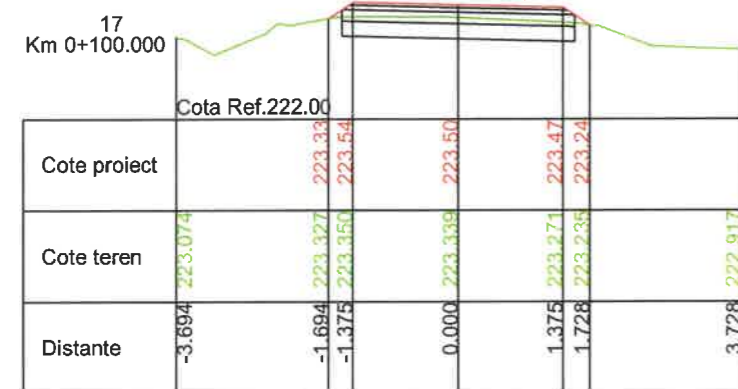



Strada Fantanitei Curve 2	
Curba nr.	2
Raza	20.00
Lungime	13.84
Tangenta	7.21
Unghi	39°39'33"

Strada Fantanitei Curve 3	
Curba nr.	3
Raza	155.00
Lungime	38.77
Tangenta	19.48
Unghi	14°19'47"

Strada Fantanitei Curve 1	
Curba nr.	1
Raza	50.00
Lungime	9.60
Tangenta	4.81
Unghi	10°59'50"

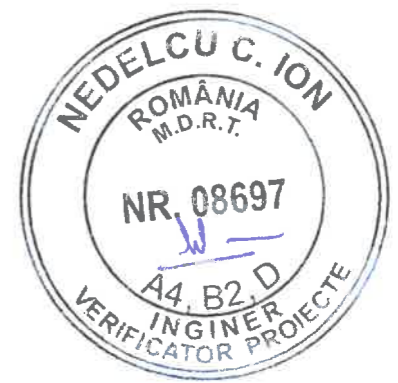

ROAD VISION DESIGN SRL
 Str. G. Mihail Cerchez, Nr. 10, Bl. A9, Ap. 3, CRAIOVA, judetul DOLJ
 J16 / 1802 / 2023, CUI - RO48687236

SCHEMA DE ASAMBLARE A PLANURILOR

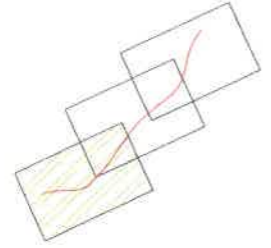

LEGENDA:

- Punct topografic
- Parte carosabila si marcaj rutier
- Ax drum proiectat
- Aerisitor instalatie gaze naturale
- Camin utilitati
- Stalp electric
- Rigola acostament
- Sant pereat
- Rigola carosabila

SPECIFICATIE	NUME	SEMNTURA	Scara:
SEF PROIECT	ing. Mihai Sorin		1:500
PROIECTAT	ing. Mihai Sorin		
DESENAT	Ing. Rotaru Cristi		Data:
VERIFICAT	Ing. Stavaru Bogdan		2023

Beneficiar:	Comuna Murgasi, Judetul Dolj	Proiect nr.	7 / 2023
Titlu proiect:	MODERNIZARE INFRASTRUCTURA RUTIERA COMUNA MURGASI, JUDETUL DOLJ	Faza:	P.T.Ex.
Titlu plansa:	PLAN DE SITUATIE Strada Fantanitei	Plansa nr.	02-PS-02-01



ava corugata, cu camera de cadere
- 5.00 m - Km: 0+194.00

Km: 0+220

Km: 0+200

Km: 0+180

Km: 0+160
Ti Km: 0+159.63

Km: 0+140

Km: 0+120

Te Km: 0+102.10
Km: 0+100

Strada Fantanitei Curve 4	
Curba nr.	4
Raza	100.00
Lungime	27.54
Tangenta	13.86
Unghi	15°46'40"

Strada Fantanitei Curve 3	
Curba nr.	3
Raza	155.00
Lungime	38.77
Tangenta	19.48
Unghi	14°19'47"

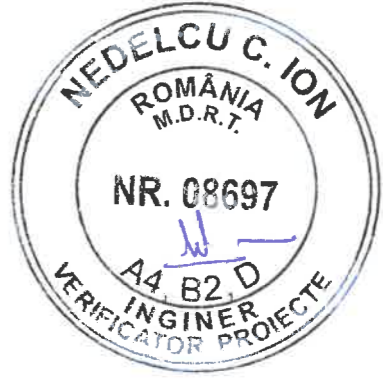

SCHEMA DE ASAMBLARE A PLANURILOR

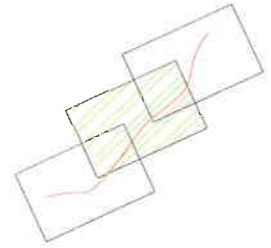

LEGENDA:

- Punct topografic
- Parte carosabila si marcaj rutier
- Ax drum proiectat
- Aerisitor instalatie gaze naturale
- Camin utilitati
- Stalp electric
- Rigola acostament
- Sant perat
- Rigola carosabila

			Beneficiar:	Comuna Murgasi, Judetul Dolj	Proiect nr.	7 / 2023	
SPECIFICATIE	NUME	SEMNTATURA	Scara:	Titlu proiect:	Faza:		
SEF PROIECT	ing. Mihai Sorin		1:500	MODERNIZARE INFRASTRUCTURA RUTIERA COMUNA MURGASI, JUDETUL DOLJ	P.T.Ex.		
PROIECTAT	ing. Mihai Sorin		Data:				
DESENAT	Ing. Rotaru Cristi		2023			Titlu plansa:	PLAN DE SITUATIE Strada Fantanitei
VERIFICAT	Ing. Stavaru Bogdan						

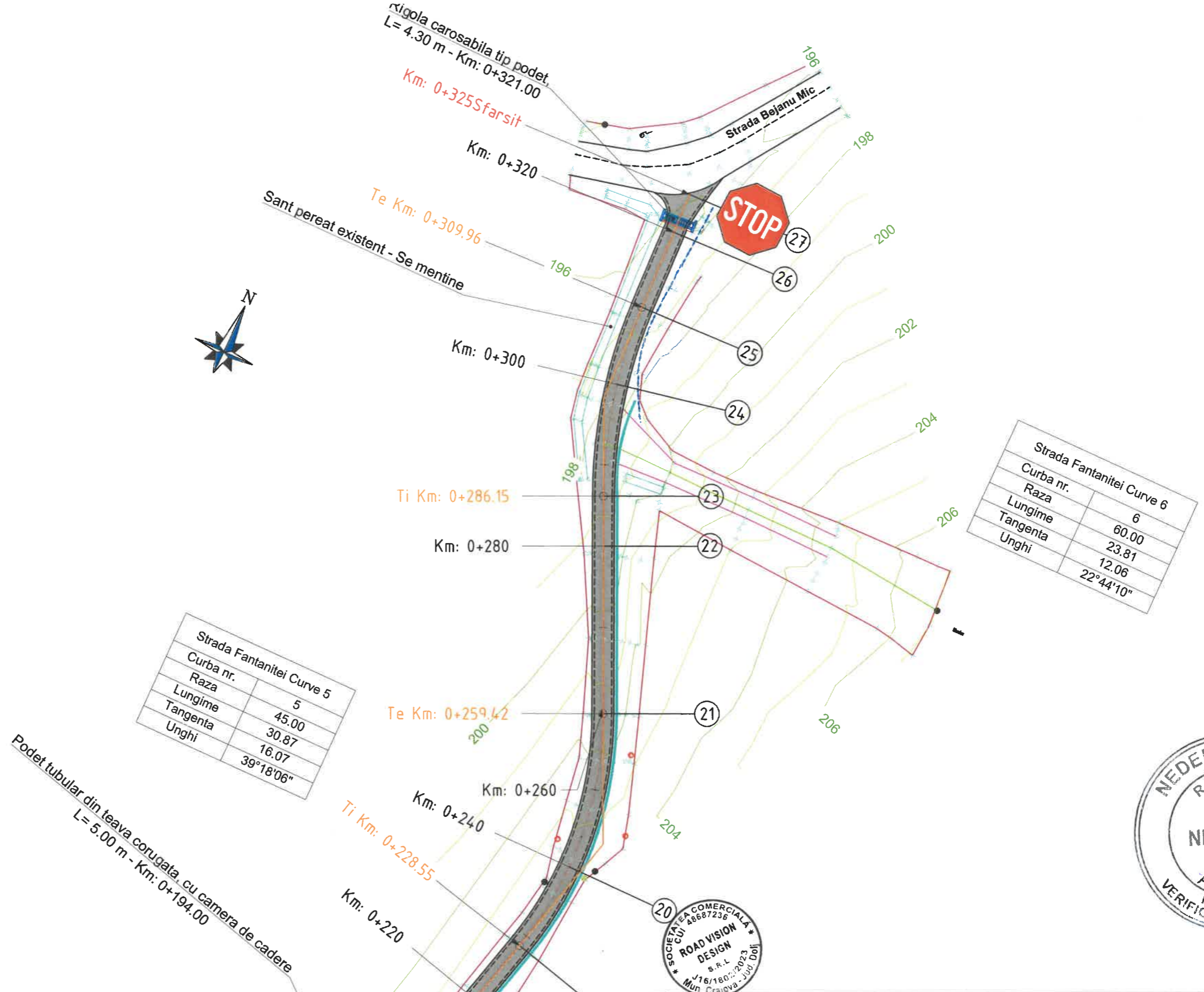

Strada Fantanitei Curve 5	
Curba nr.	5
Raza	45.00
Lungime	30.87
Tangenta	16.07
Unghi	39°18'06"

Strada Fantanitei Curve 6	
Curba nr.	6
Raza	60.00
Lungime	23.81
Tangenta	12.06
Unghi	22°44'10"

Podet tubular din teava corugata, cu camera de cadere
L= 5.00 m - Km: 0+194.00

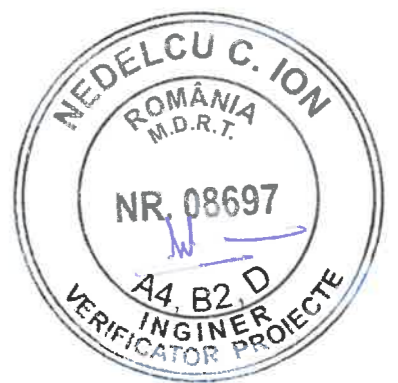

SCHEMA DE ASAMBLARE A PLANURILOR

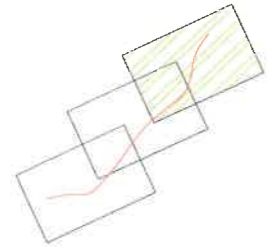

LEGENDA:

- Punct topografic
- Parte carosabila si marcaj rutier
- Ax drum proiectat
- Aerisitor instalatie gaze naturale
- Camin utilitati
- Stalp electric
- Rigola acostament
- Sant pereat
- Rigola carosabila

ROAD VISION DESIGN SRL
Str. G. Mihail Cerchez, Nr. 10, Bl. A9, Ap. 3, CRAIOVA, judetul DOLJ
J16 / 1802 / 2023, CUI - RO48687236

SPECIFICATIE	NUME	SEMNATURA	Scara:
SEF PROIECT	ing. Mihai Sorin		1:500
PROIECTAT	ing. Mihai Sorin		
DESENAT	Ing. Rotaru Cristi		Data: 2023
VERIFICAT	Ing. Stavaru Bogdan		

Beneficiar:	Comuna Murgasi, Judetul Dolj	Proiect nr.	7 / 2023
Titlu proiect:	MODERNIZARE INFRASTRUCTURA RUTIERA COMUNA MURGASI, JUDETUL DOLJ	Faza:	P.T.Ex.
Titlu plansa:	PLAN DE SITUATIE Strada Fantanitei	Plansa nr.	02-PS-02-03



BENEFICIAR:
**Comuna Murgasi,
Judetul Dolj**

DENUMIREA PROIECTULUI:
**Modernizare infrastructura rutiera
comuna Murgasi, Judetul Dolj**

PROIECTANT:
**ROAD VISION
DESIGN SRL**
Str. G. Mihail Cerchez, Nr. 10, Bl. A9, Ap. 3,
CRAIOVA, judetul DOLJ
116 / 1802 / 2023, CUI - RO48687236

LEGENDA:
— Linie proiect
— Linie teren
- - - Linie sant dreapta
- - - Linie sant stanga

● KM = 0+053.22
mi (%) = 12.50
me (%) = 11.20
m (%) = 1.30
R (m) = 2860
T (m) = 18.58
B (cm) = 6.03
L (m) = 37.16

Schimbator panou

VERIFICATOR:
SEMNATURA
CERINTA: A4, B2, D

EXPERT:
SEMNATURA
CERINTA: A4, B2, D

SEF PROIECT
Ing. Mihai Sorin

Proiectat: **Ing. Mihai Sorin**
Desenat: **Ing. Rotaru Cristi**

TITLU PLANSA:
**PROFIL LONGITUDINAL
Srada Fantanitei**

SCARA:
1:1000-L
1:100-H

PROIECT: 7/2023
DATA: 2023
FAZA DE PROIECTARE: P.T.Ex.
PLANSA NR.: 03-PL-02-01
REVIZIA NR.: 0

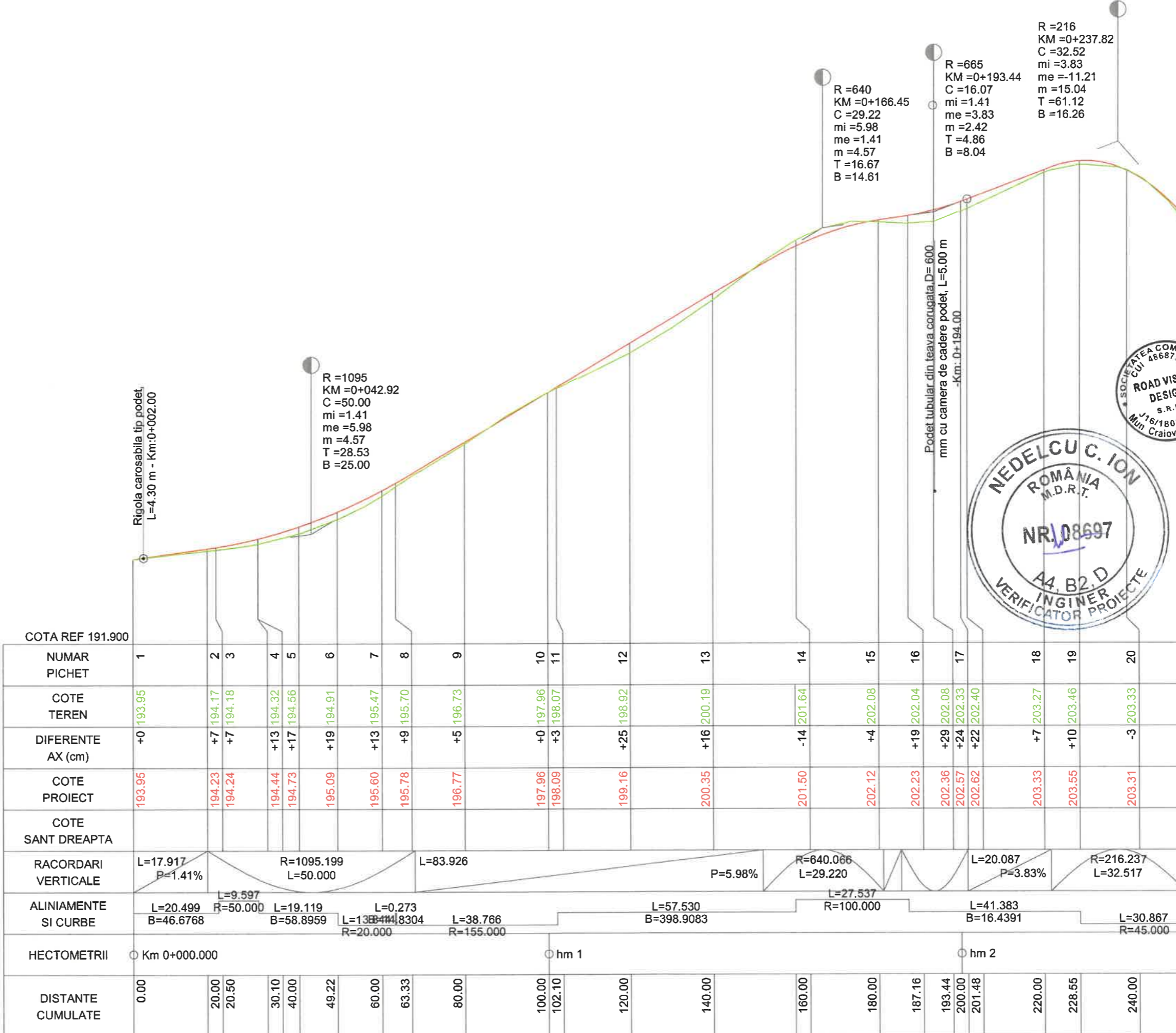

PROFIL LONGITUDINAL Strada Fantanitei DE LA 0.000 LA 325.000 SCARA : ORIZ 1 :1000 VERT 1 :100





BENEFICIAR:

**Comuna Murgasi,
Judetul Dolj**

DENUMIREA PROIECTULUI:

**Modernizare infrastructura rutiera
comuna Murgasi, Judetul Dolj**

PROIECTANT:



LEGENDA:

- Linie proiect
- Linie teren
- - - Linie sant dreapta
- - - Linie sant stanga

● KM = 0+053.22
 mi (%) = 12.50
 me (%) = 11.20
 m (%) = 1.30
 R (m) = 2860
 T (m) = 18.58
 B (cm) = 6.03
 L (m) = 37.16
 Schimbator panou

VERIFICATOR:

SEMNATURA

CERINTA: A4, B2, D

EXPERT:

SEMNATURA

CERINTA: A4, B2, D

SEF PROIECT

Ing. Mihai Sorin
M.S.

Proiectat Ing. Mihai Sorin <i>M.S.</i>	Desenat Ing. Rotaru Cristi <i>R.C.</i>
---	---

TITLU PLANSĂ:

**PROFIL LONGITUDINAL
Strada Fantanitei**

SCARA:
1:1000-L
1:100-H

PROIECT: 7/2023

DATA: 2023

FAZA DE PROIECTARE: P.T.Ex.

PLANSĂ NR.: 03-PL-02-02

REVIZIA NR.: 0

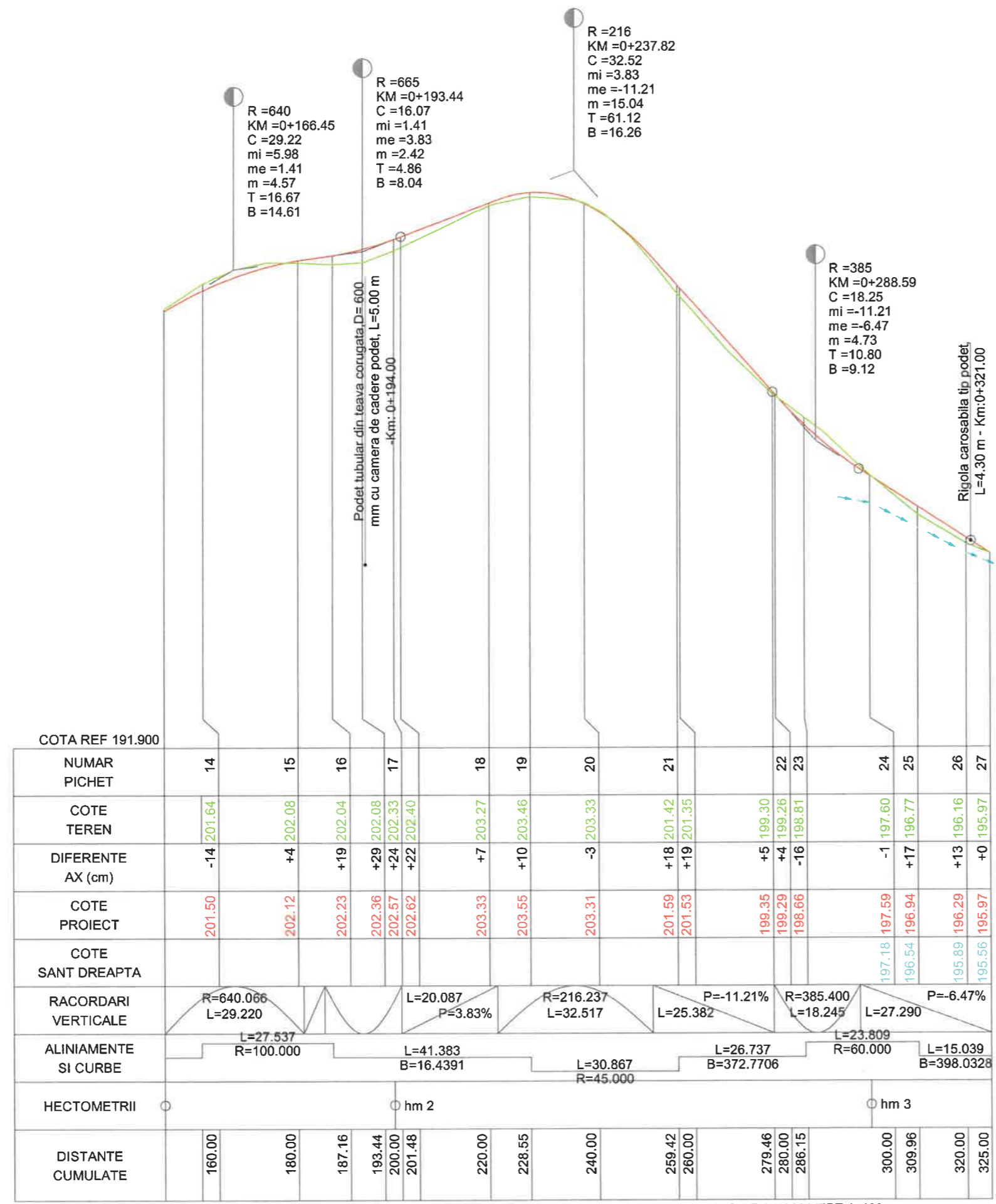

PROFIL LONGITUDINAL Strada Fantanitei DE LA 0.000 LA 325.000 SCARA : ORIZ 1 :1000 VERT 1 :100



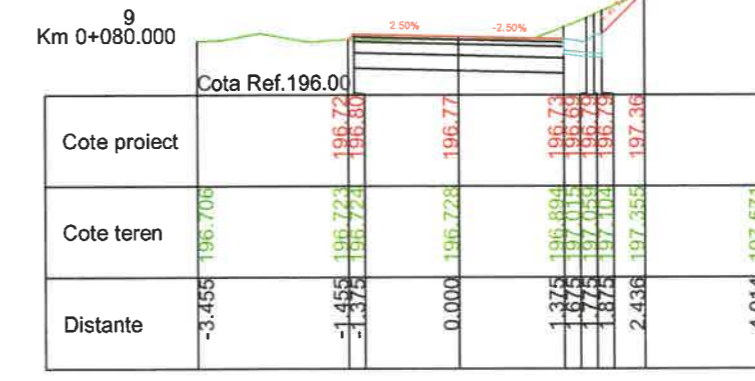
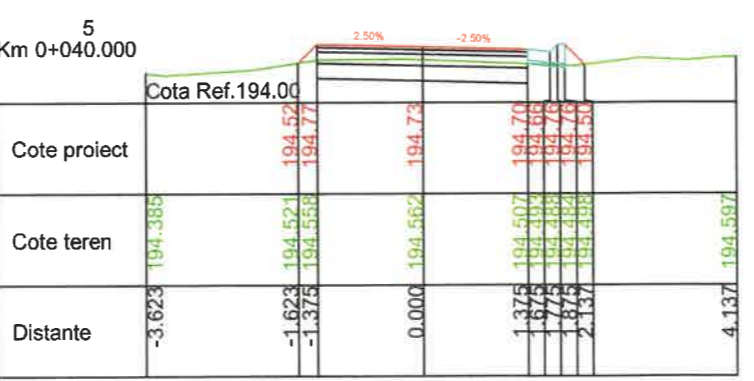
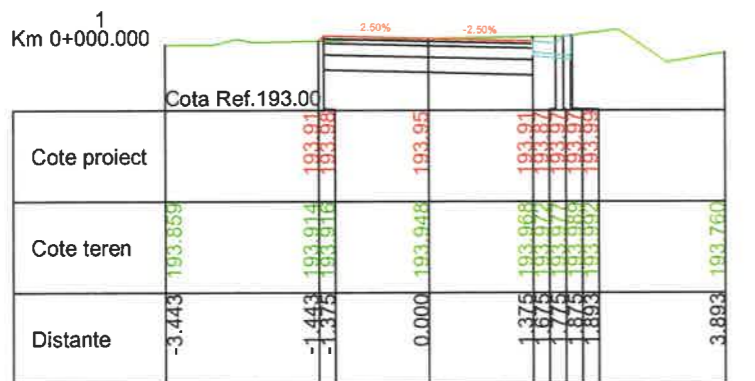
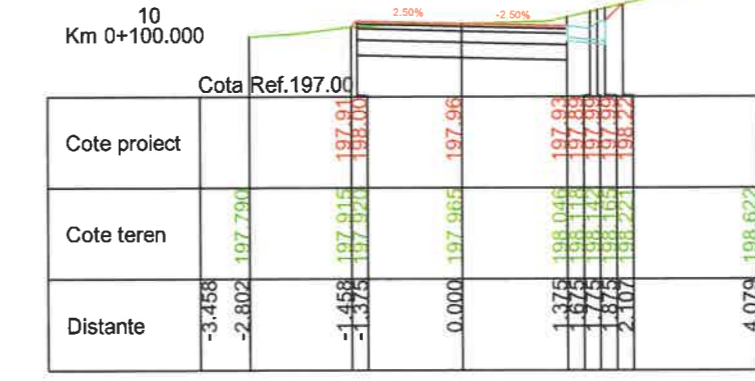
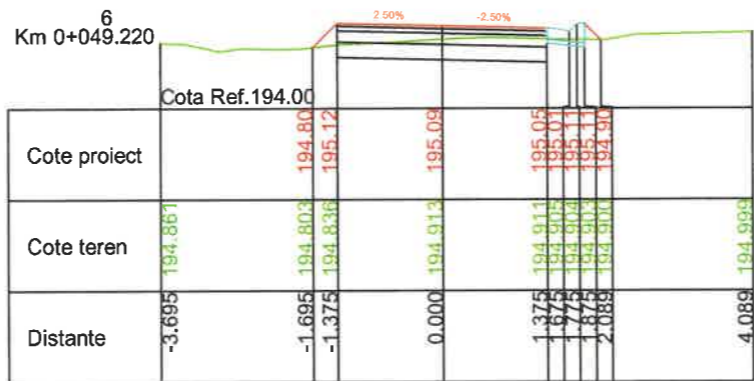
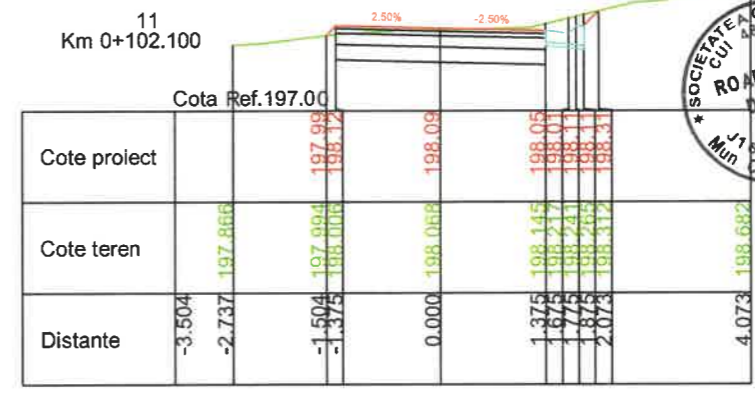
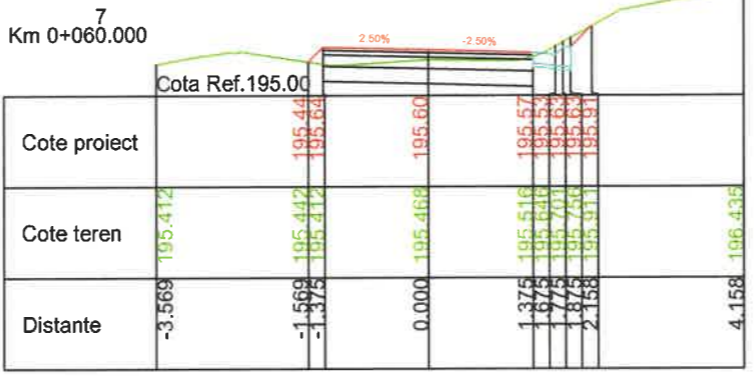
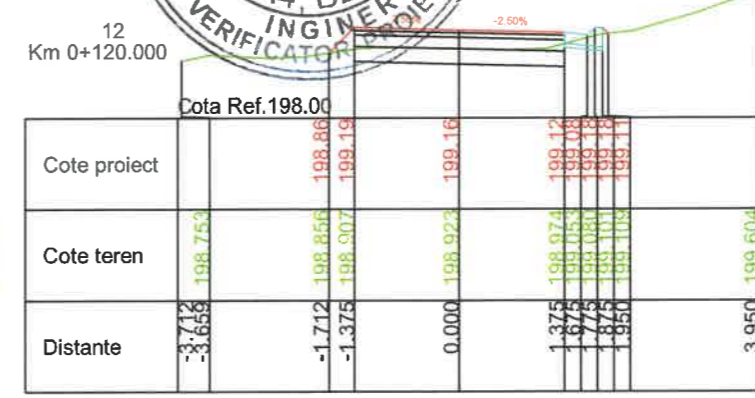
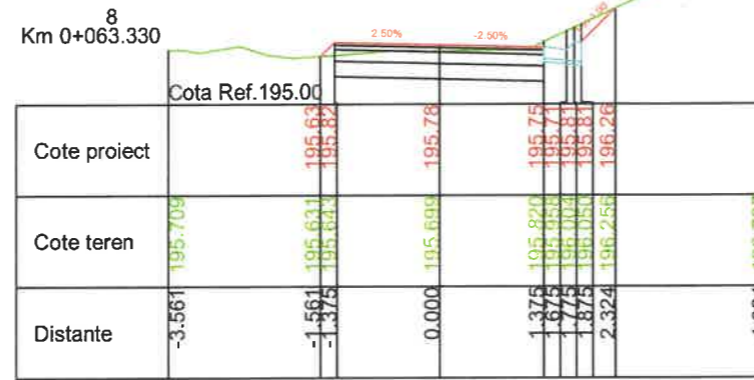

BENEFICIAR:
Comuna Murgasi, Judetul Dolj

DENUMIREA PROIECTULUI:
Modernizare infrastructura rutiera comuna Murgasi, Judetul Dolj

PROIECTANT:
ROAD VISION DESIGN SRL
Sir. G. Mihail Carchez, Nr. 10, Bl. A9, Ap. 3, CRAIOVA, judetul DOLJ
116 / 1802 / 2023, CUI - RO48687238

LEGENDA:
— Linie proiect
— Linie teren

VERIFICATOR:
SEMNATURA
CERINTA: A4, B2, D

EXPERT:
SEMNATURA
CERINTA: A4, B2, D

SEF PROIECT
Ing. Mihai Sorin

Proiectat: Ing. Mihai Sorin
Desenat: Ing. Rotaru Cristi

TITLU PLANSA:
PROFILE TRANSVERSALE Strada Fantanitei

SCARA:
1:100

PROIECT: 7/2023
DATA: 2023
FAZA DE PROIECTARE: P.T.Ex.
PLANSĂ NR.: 04-PT-02-01
REVIZIA NR.: 0

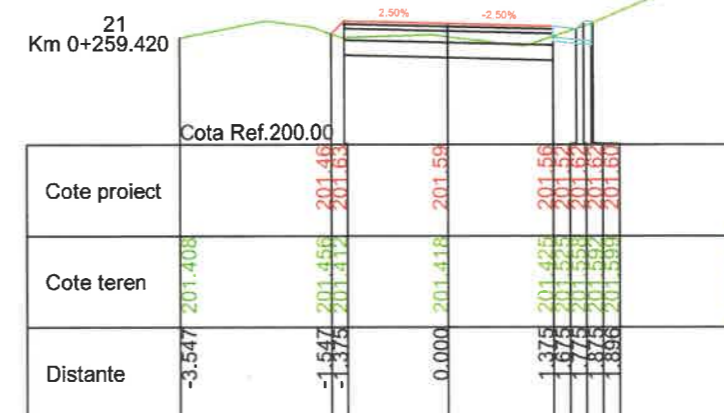
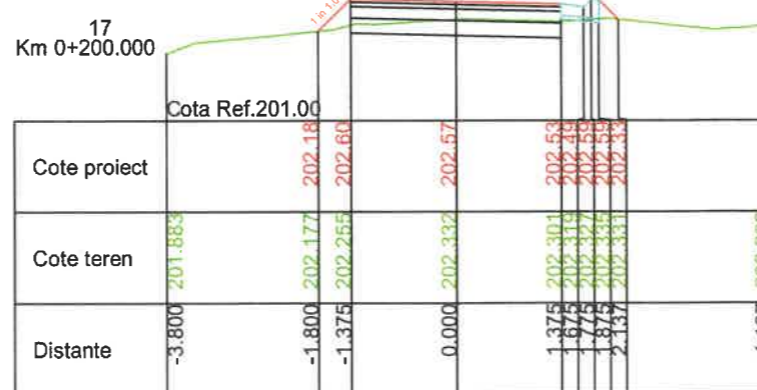
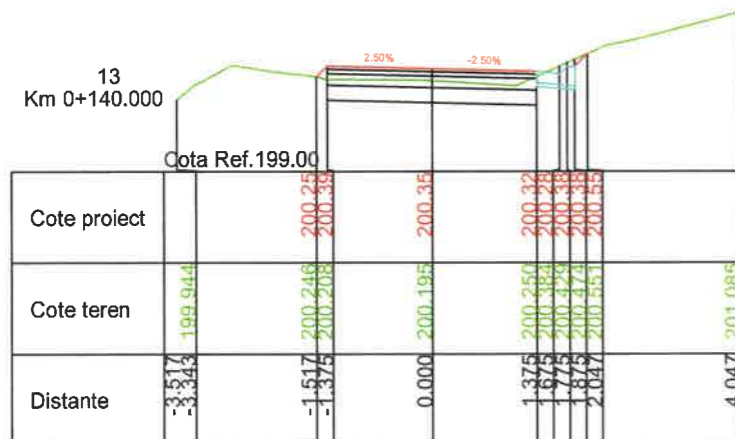
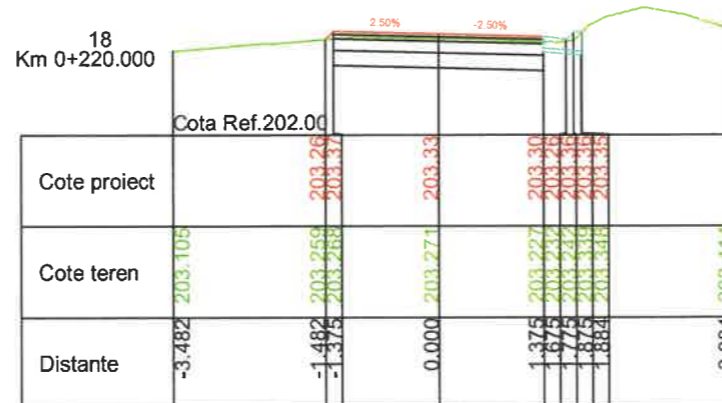
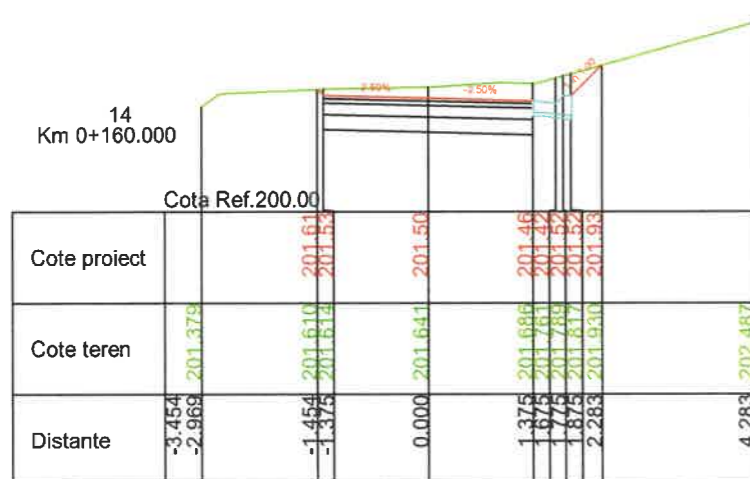
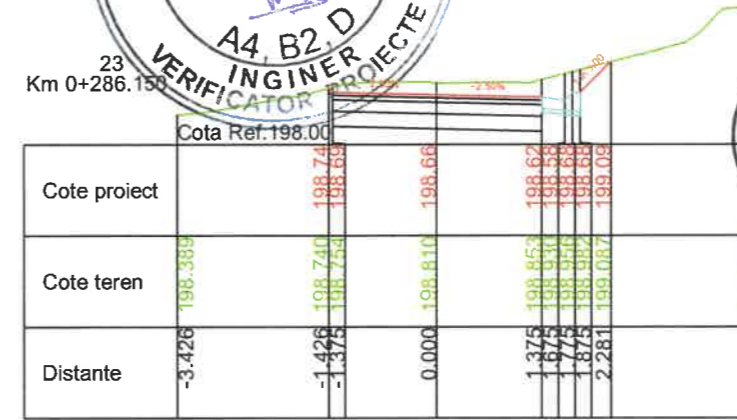
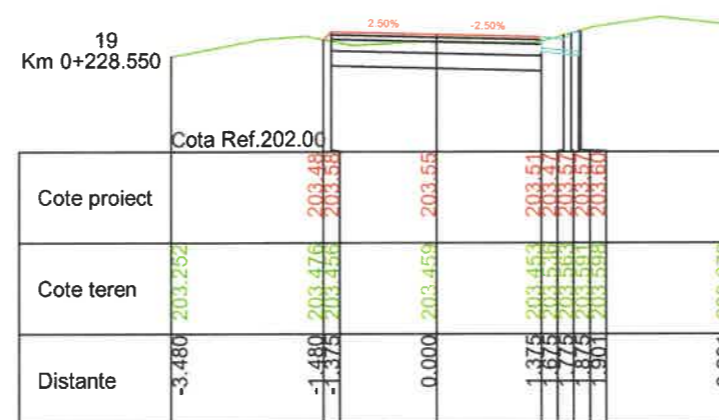
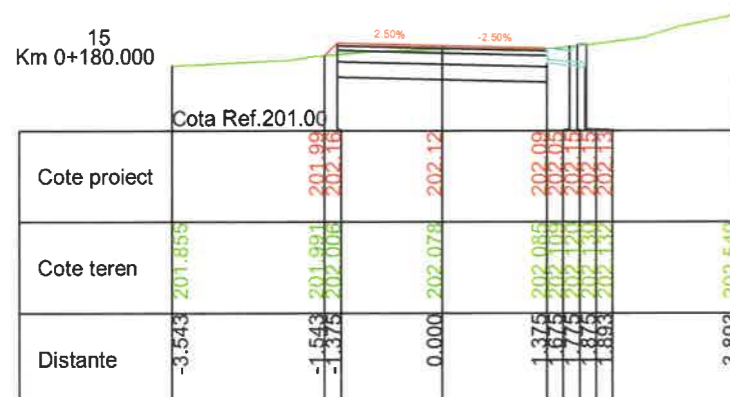
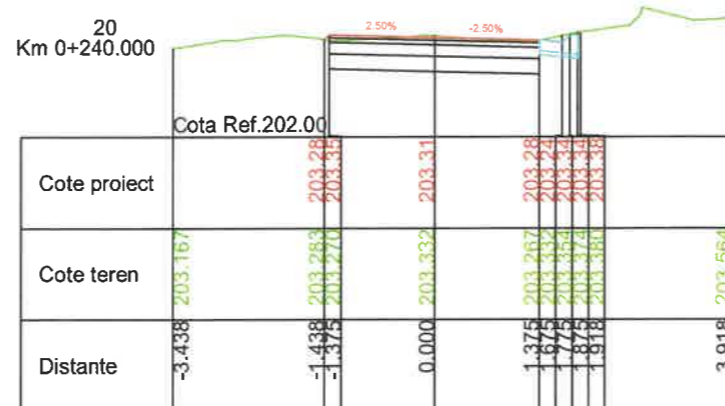
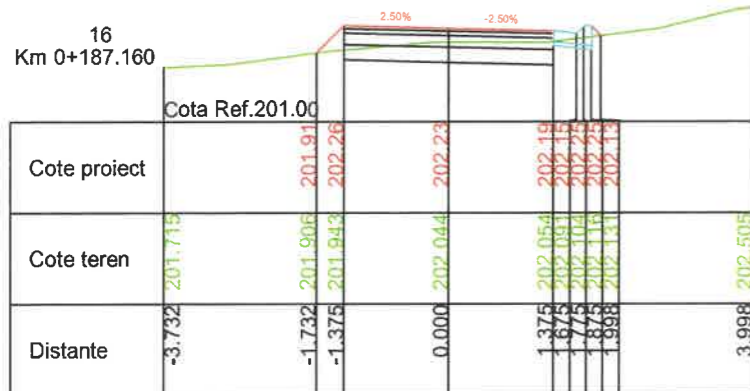

BENEFICIAR:

Comuna Murgasi,
Judetul Dolj

DENUMIREA PROIECTULUI:

Modernizare infrastructura rutiera
comuna Murgasi, Judetul Dolj

PROIECTANT:



LEGENDA:

- Linie proiect
- Linie teren

VERIFICATOR:

SEMNATURA

CERINTA: A4, B2, D

EXPERT:

SEMNATURA

CERINTA: A4, B2, D

SEF PROIECT

Ing. Mihai Sorin

Proiectat Desenat

Ing. Mihai Sorin Ing. Rotaru Cristi

TITLU PLANSA:

PROFILE TRANSVERSALE
Strada Fantanitei

SCARA:

1:100

PROIECT: 7/2023

DATA: 2023

FAZA DE PROIECTARE P.T.Ex.

PLANSA NR. 04-PT-02-02

REVIZIA NR. 0



BENEFICIAR:
**Comuna Murgasi,
Judetul Dolj**

DENUMIREA PROIECTULUI:
**Modernizare infrastructura rutiera
comuna Murgasi, Judetul Dolj**

PROIECTANT:
**ROAD VISION
DESIGN SRL**
S.R.L.
Str. G. Mihail Carchez, Nr. 10, Bl. A9, Ap. 3,
CRAIOVA, judetul DOLJ
16 / 1802 / 2023, CUI - RO48687236



LEGENDA:
— Linie proiect
— Linie teren

VERIFICATOR:
SEMNATURA
CERINTA: A4, B2, D

EXPERT:
SEMNATURA
CERINTA: A4, B2, D

SEF PROIECT
Ing. Mihai Sorin

Proiectat Ing. Mihai Sorin	Desenat Ing. Rotaru Cristi
--------------------------------------	--------------------------------------

TITLU PLANSĂ:
**PROFILE TRANSVERSALE
Strada Fantanitei**

SCARA:
1:100

PROIECT:	7/2023
DATA:	2023
FAZA DE PROIECTARE	P.T.Ex.
PLANSĂ NR.	04-PT-02-03
REVIZIA NR.	0

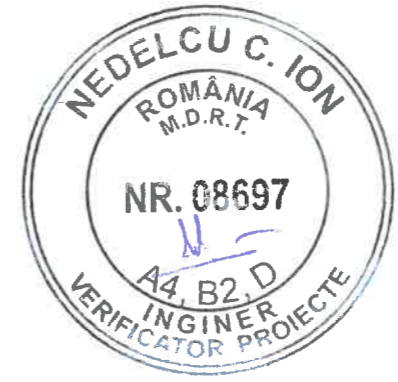
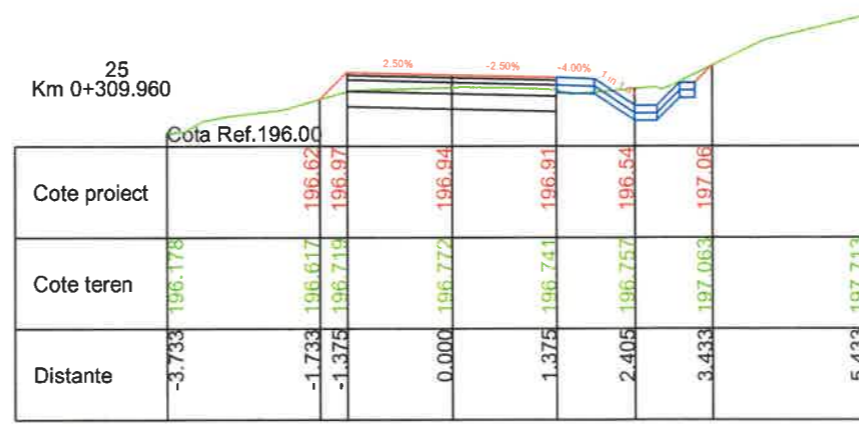
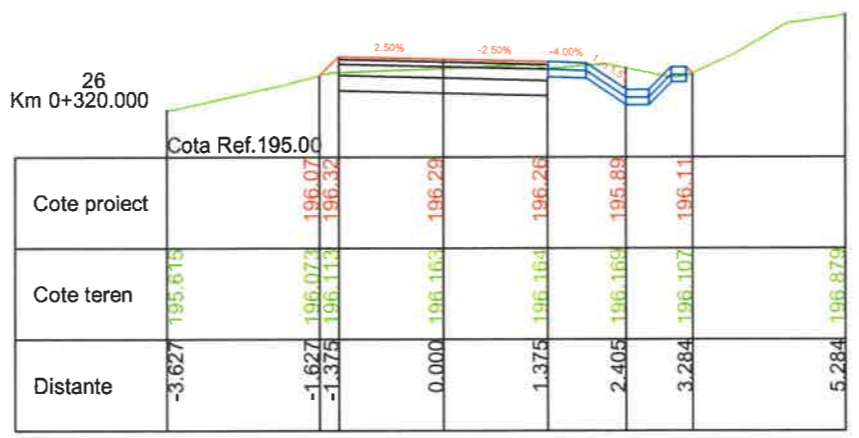
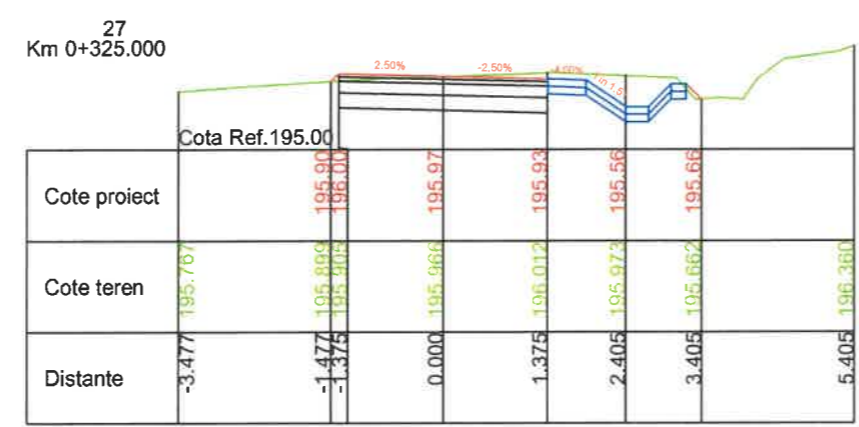

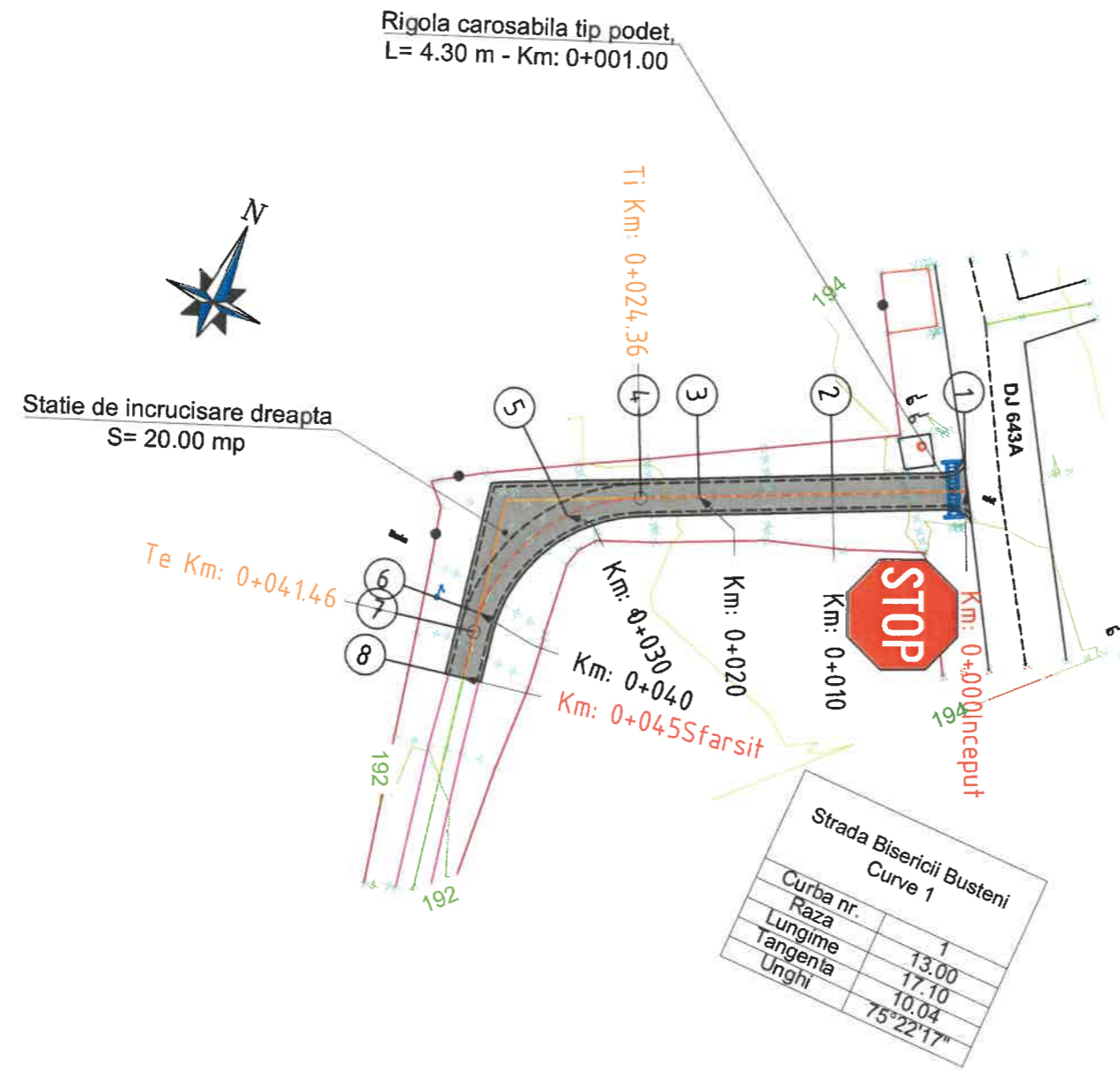

Strada Bisericii Busteni Curve 1	
Curba nr.	1
Raza	13.00
Lungime	17.10
Tangenta	10.04
Unghi	75°22'17"

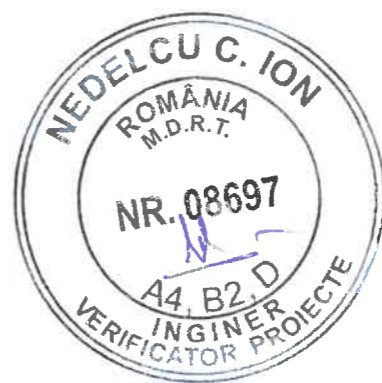

SCHEMA DE ASAMBLARE A PLANURILOR



LEGENDA:

- Punct topografic
- Parte carosabila si marcaj rutier
- Ax drum proiectat
- Aerisitor instalatie gaze naturale
- Camin utilitati
- Stalp electric
- Rigola acostament
- Sant pereat
- Rigola carosabila

ROAD VISION DESIGN SRL

Str. G. Mihail Cerchez, Nr. 10, Bl. A9, Ap. 3, CRAIOVA, judetul DOLJ
J16 / 1802 / 2023, CUI - RO48687236

SPECIFICATIE	NUME	SEMNATURA	Scara:
SEF PROIECT	ing. Mihai Sorin		1:500
PROIECTAT	ing. Mihai Sorin		
DESENAT	ing. Rotaru Cristi		Data: 2023
VERIFICAT	ing. Stavaru Bogdan		

Beneficiar:	Comuna Murgasi, Judetul Dolj	Proiect nr.	7 / 2023
Titlu proiect:	MODERNIZARE INFRASTRUCTURA RUTIERA COMUNA MURGASI, JUDETUL DOLJ	Faza:	P.T.Ex.
Titlu plansa:	PLAN DE SITUATIE Strada Bisericii Busteni	Plansa nr.	02-PS-03-01



BENEFICIAR:

**Comuna Murgasi,
Judetul Dolj**

DENUMIREA PROIECTULUI:

**Modernizare infrastructura rutiera
comuna Murgasi, Judetul Dolj**

PROIECTANT:



LEGENDA:

- Linie proiect
- Linie teren
- - - Linie sant dreapta
- - - Linie sant stanga

KM =0+053.22
 mi (%) =12.50
 me (%) =11.20
 m (%) =1.30
 R (m) =2860
 T (m) =18.58
 B (cm) =6.03
 L (m) =37.16
 Schimbator panou

VERIFICATOR:

SEMNATURA

CERINTA: A4, B2, D

EXPERT:

SEMNATURA

CERINTA: A4, B2, D

SEF PROIECT

Ing. Mihai Sorin

Mihai Sorin

Proiectat Ing. Mihai Sorin

Mihai Sorin

Desenat Ing. Rotaru Cristi

Rotaru Cristi

TITLU PLANSA:

**PROFIL LONGITUDINAL
Strada Bisericii Busteni**

SCARA:

1:1000-L
1:100-H

PROIECT: 7/2023

DATA: 2023

FAZA DE PROIECTARE P.T.Ex.

PLANSA NR. 03-PL-03-01

REVIZIA NR. 0

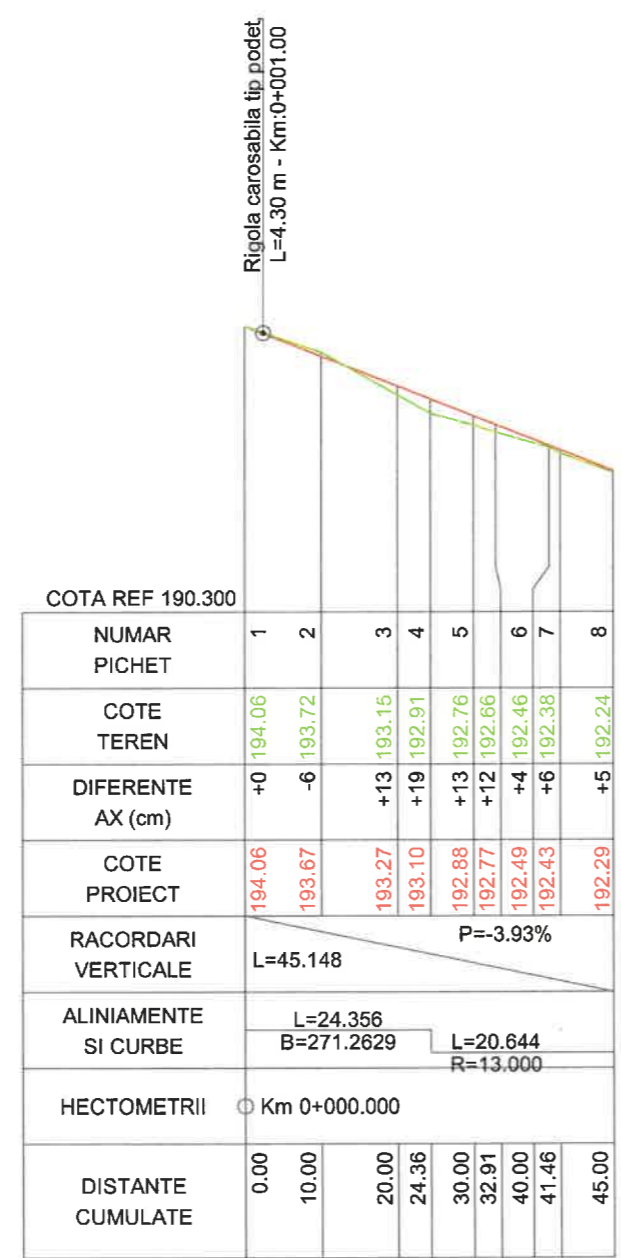

PROFIL LONGITUDINAL Strada Bisericii Busteni DE LA 0.000 LA 45.000 SCARA : ORIZ 1 :1000 VERT 1 :100

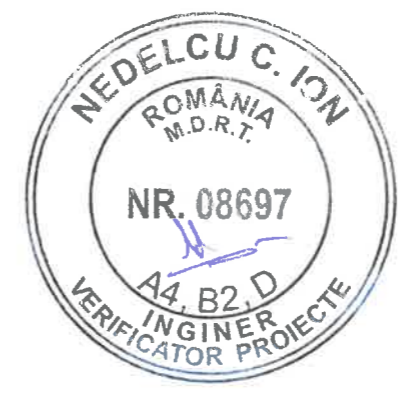

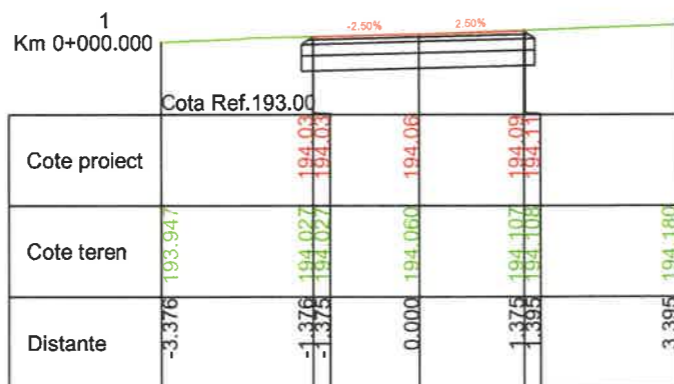
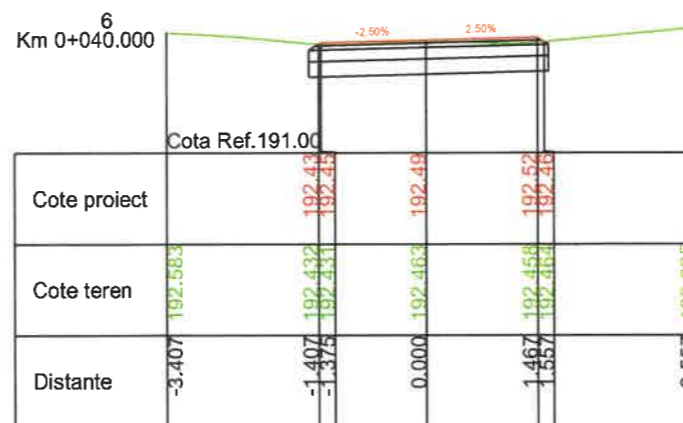
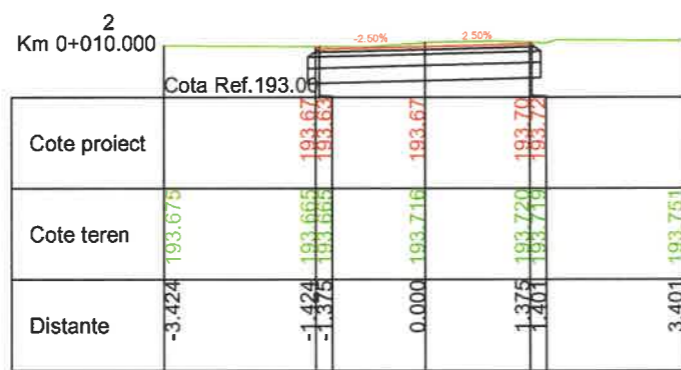
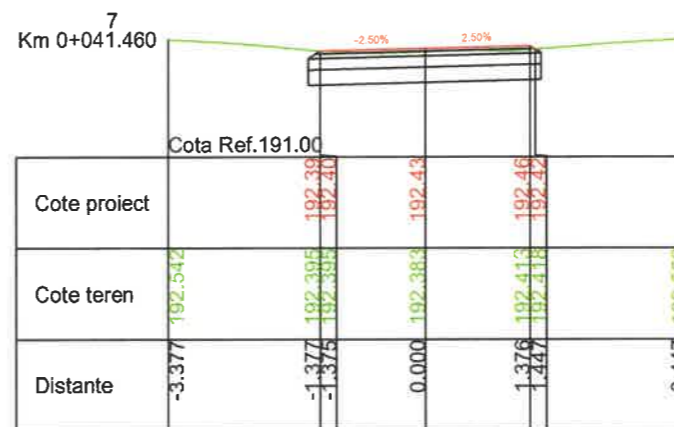
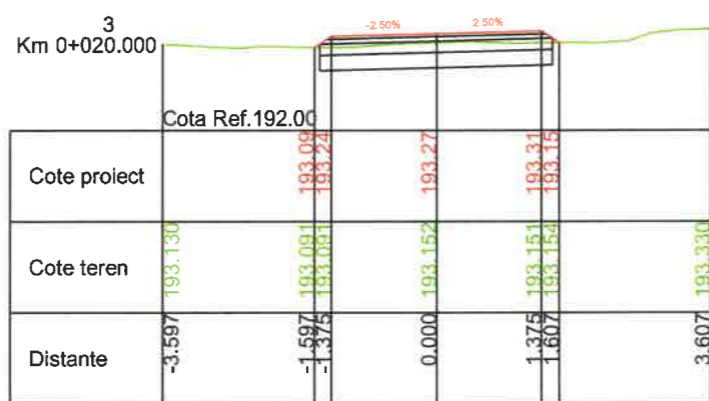
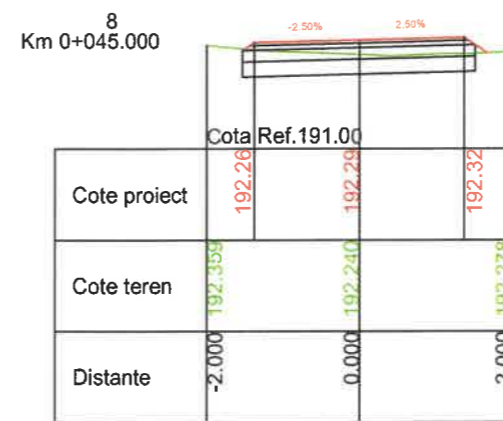

BENEFICIAR:

Comuna Murgasi,
Judetul Dolj

DENUMIREA PROIECTULUI:

Modernizare infrastructura rutiera
comuna Murgasi, Judetul Dolj

PROIECTANT:

**ROAD VISION
DESIGN SRL**
Str. G. Mihail Cerchez, Nr. 10, Bl. A9, Ap. 3
CRAIOVA, judetul DOLJ
116 / 1802 / 2023, CUI - RO48687236

LEGENDA:

— Linie proiect
— Linie teren

VERIFICATOR:

SEMNTURA

CERINTA: A4, B2, D

EXPERT:

SEMNTURA

CERINTA: A4, B2, D

SEF PROIECT

Ing. Mihai Sorin

Proiectat Ing. Mihai Sorin

Desenat Ing. Rotaru Cristi

TITLU PLANSA:

PROFILE TRANSVERSALE
Strada Bisericii Busteni

SCARA:

1:100

PROIECT: 7/2023

DATA: 2023

FAZA DE PROIECTARE P.T.Ex.

PLANSA NR. 04-PT-03-01

REVIZIA NR. 0

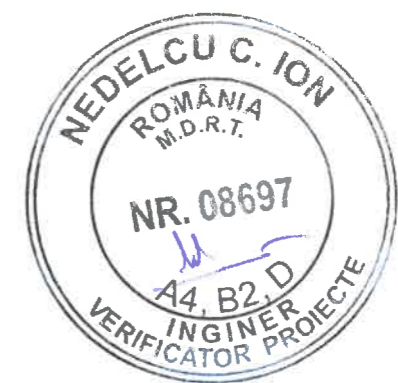
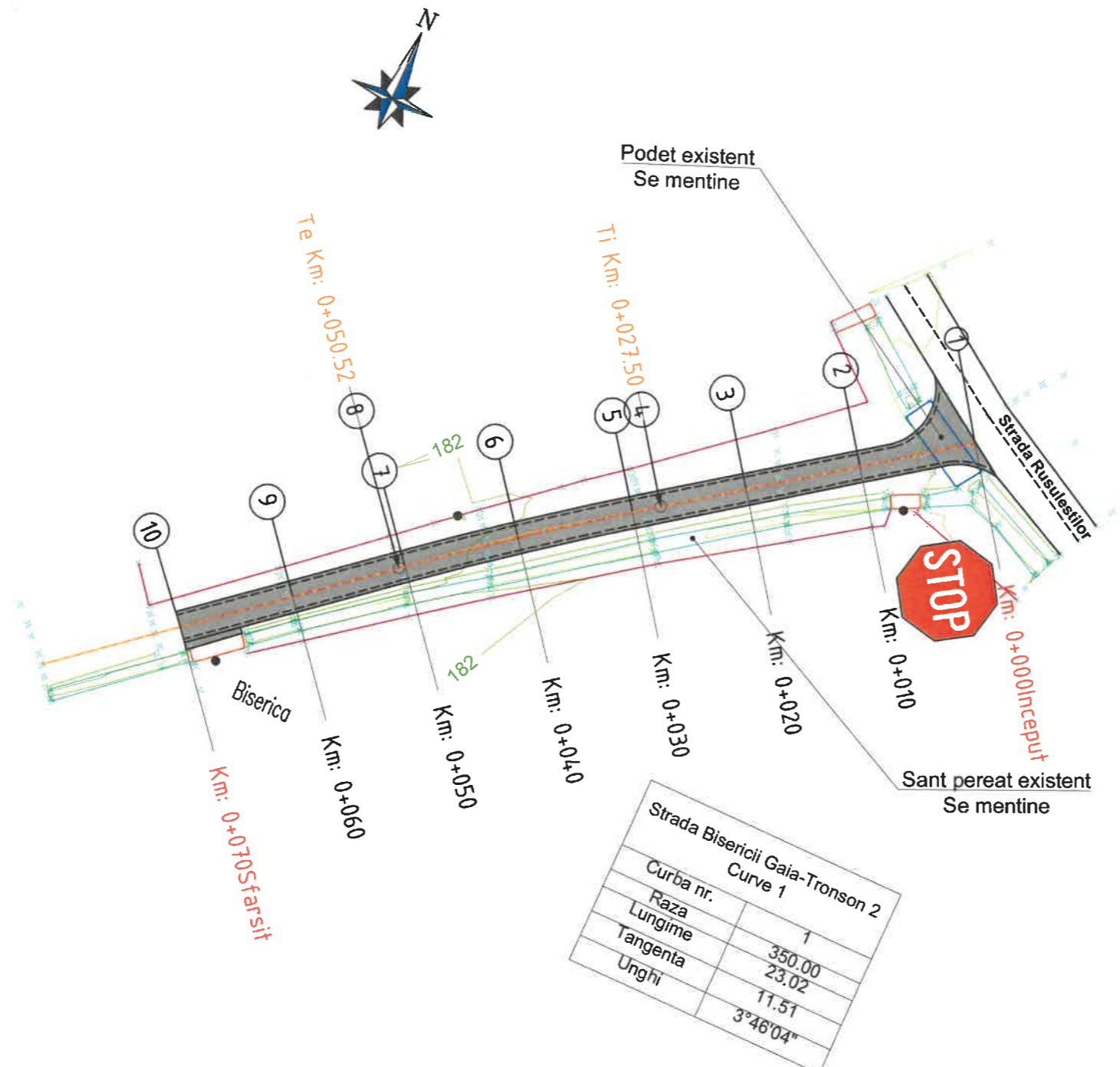

SCHEMA DE ASAMBLARE A PLANURILOR

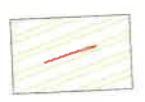

LEGENDA:

- Punct topografic
- Parte carosabila si marcaj rutier
- Ax drum proiectat
- Aerisor instalatie gaze naturale
- Camin utilitati
- Stalp electric
- Rigola acostament
- Sant peret
- Rigola carosabila

ROAD VISION DESIGN SRL Str. G. Mihail Cerchez, Nr. 10, Bl. A9, Ap. 3, CRAIOVA, judetul DOLJ J16 / 1802 / 2023, CUI - RO48687236				Beneficiar:	Proiect nr.
				Comuna Murgasi, Judetul Dolj	7 / 2023
SPECIFICATIE	NUME	SEMNATURA	Scara:	Titlu proiect:	Faza:
SEF PROIECT	ing. Mihai Sorin		1:500	MODERNIZARE INFRASTRUCTURA RUTIERA COMUNA MURGASI, JUDETUL DOLJ	P.T.Ex.
PROIECTAT	ing. Mihai Sorin		Data:		
DESENAT	ing. Rotaru Cristi		2023	Titlu plansa:	Plansa nr.
VERIFICAT	ing. Stavaru Bogdan			PLAN DE SITUATIE Strada Bisericii Gaia-Tronson 2	02-PS-04-01



BENEFICIAR:

**Comuna Murgasi,
Judetul Dolj**

DENUMIREA PROIECTULUI:

**Modernizare infrastructura rutiera
comuna Murgasi, Judetul Dolj**

PROIECTANT:

ROAD VISION DESIGN SRL
S.R.L.
Str. G. Mihail Carchez, Nr. 10, Bl. A9, Ap. 3
ERAIOVA, judetul DOLJ
116 / 1802 / 2023, CUI - RO-48687236

LEGENDA:

- Linie proiect
- Linie teren
- - - Linie sant dreapta
- - - Linie sant stanga

Schimbator panou

KM =0+053.22
mi (%) =12.50
me (%) =11.20
m (%) =1.30
R (m) =2860
T (m) =18.58
B (cm) =6.03
L (m) =37.16

VERIFICATOR:

SEMNTURA

CERINTA: A4, B2, D

EXPERT:

SEMNTURA

CERINTA: A4, B2, D

SEF PROIECT
Ing. Mihai Sorin

Proiectat Ing. Mihai Sorin	Desenat Ing. Rotaru Cristi
--------------------------------------	--------------------------------------

TITLU PLANSA:

**PROFIL LONGITUDINAL
Strada Bisericii Gaia-Tronson 2**

SCARA:
1:1000-L
1:100-H

PROIECT: 7/2023

DATA: 2023

FAZA DE PROIECTARE: P.T.Ex.

PLANSA NR. 03-PL-04-01

REVIZIA NR. 0

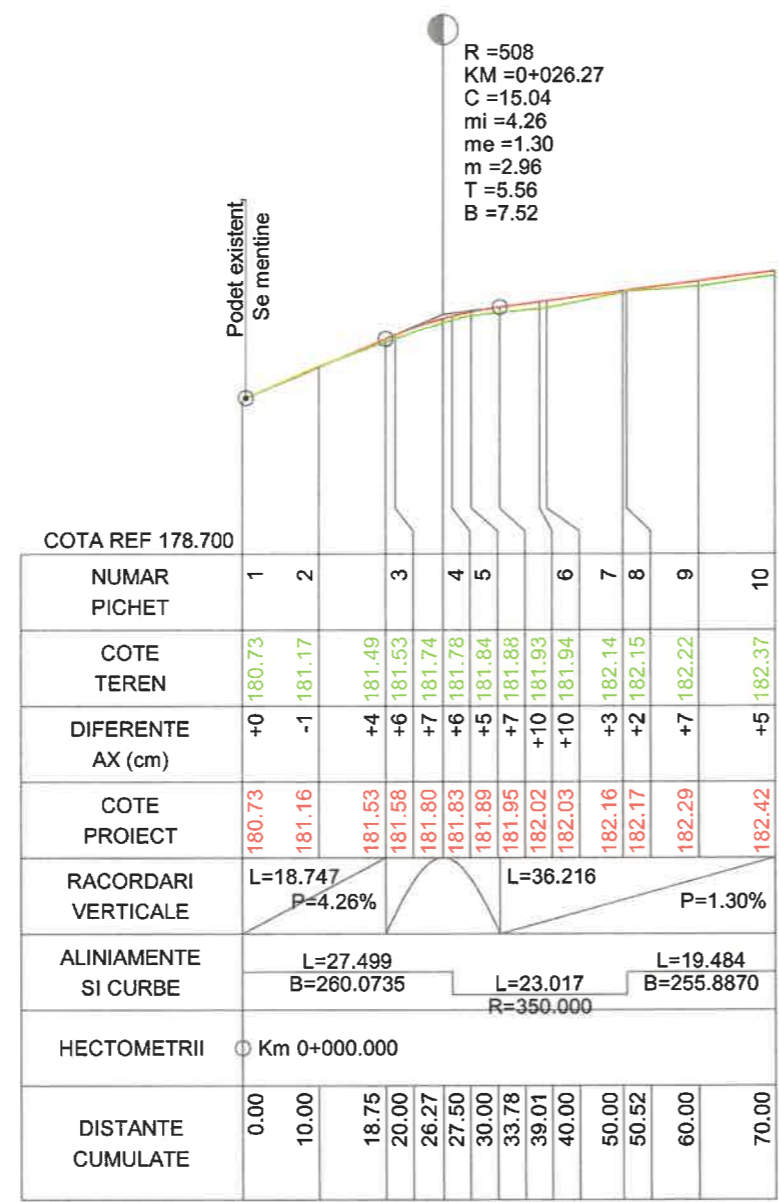

PROFIL LONGITUDINAL Strada Bisericii Gaia-Tronson 2 DE LA 0.000 LA 70.000 SCARA : ORIZ 1 :1000 VERT 1 :100

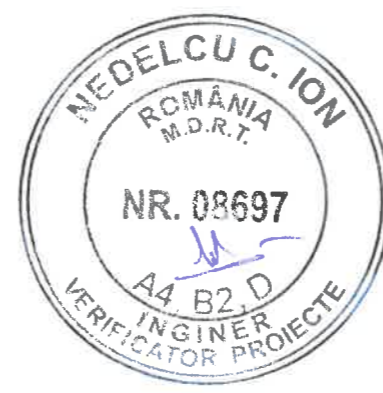



BENEFICIAR:

**Comuna Murgasi,
Judetul Dolj**

DENUMIREA PROIECTULUI:

**Modernizare infrastructura rutiera
comuna Murgasi, Judetul Dolj**

PROIECTANT:



LEGENDA:

— Linie proiect
— Linie teren

VERIFICATOR:

SEMNATURA

CERINTA: A4, B2, D

EXPERT:

SEMNATURA

CERINTA: A4, B2, D

SEF PROIECT

Ing. Mihai Sorin

Proiectat Ing. Mihai Sorin

Desenat Ing. Rotaru Cristi

TITLU PLANSA:

**PROFILE TRANSVERSALE
Strada Bisericii Gaia - Tronson 2**

SCARA:

1:100

PROIECT: 7/2023

DATA: 2023

FAZA DE PROIECTARE P.T.Ex.

PLANSĂ NR. 04-PT-04-01

REVIZIA NR. 0

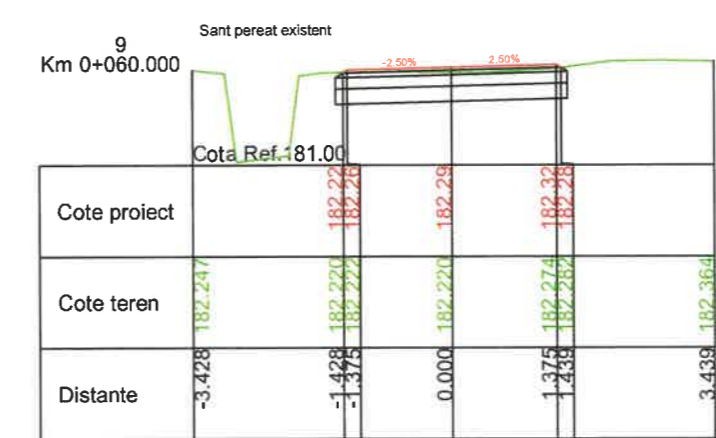
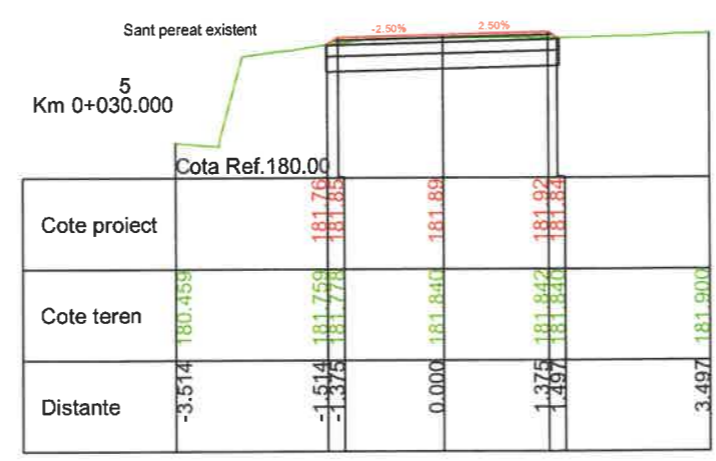
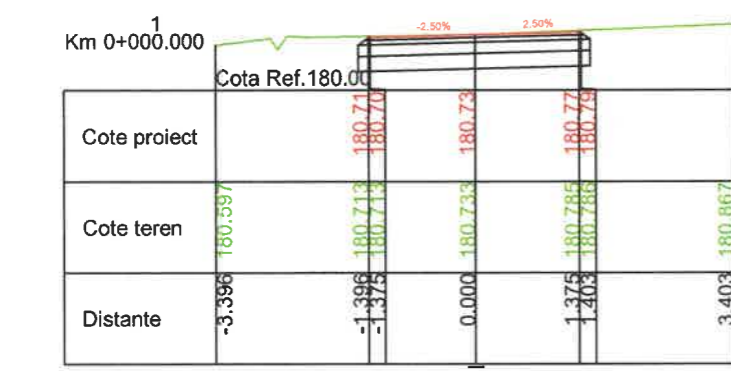
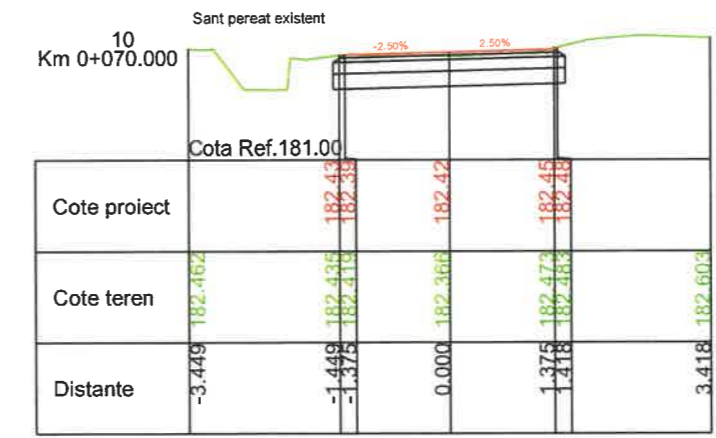
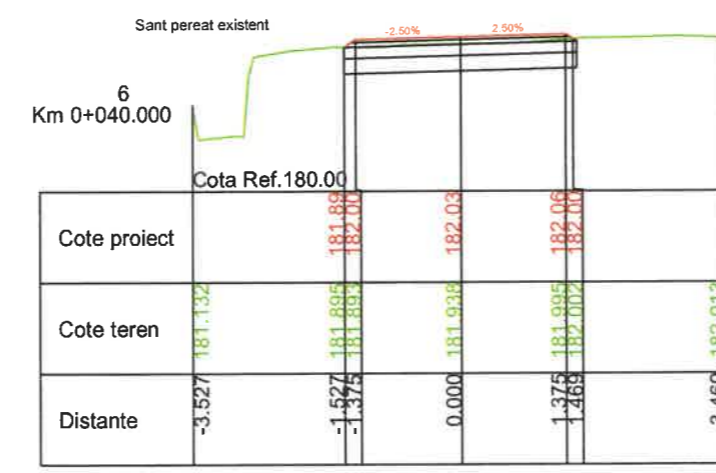
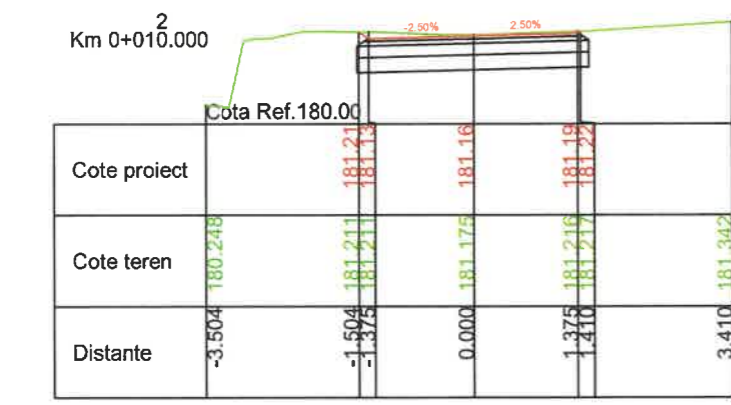
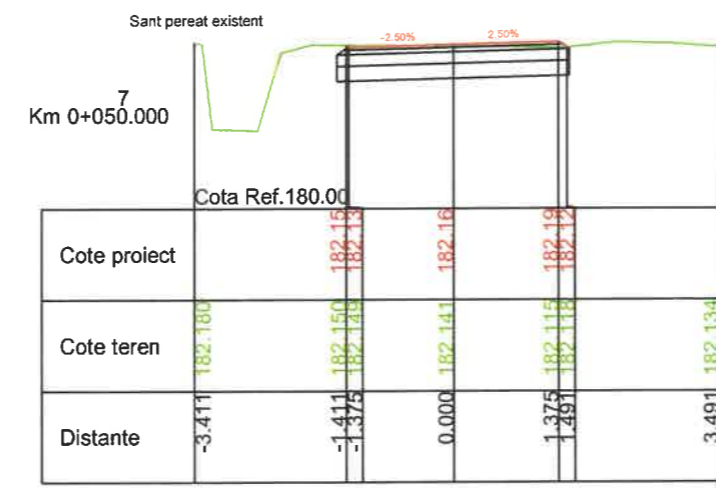
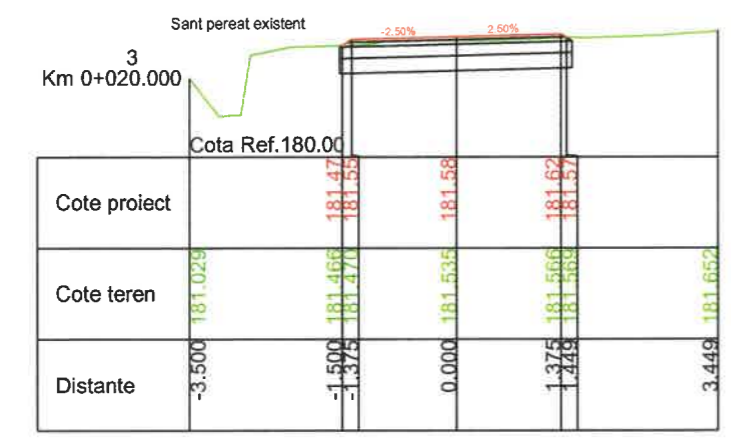
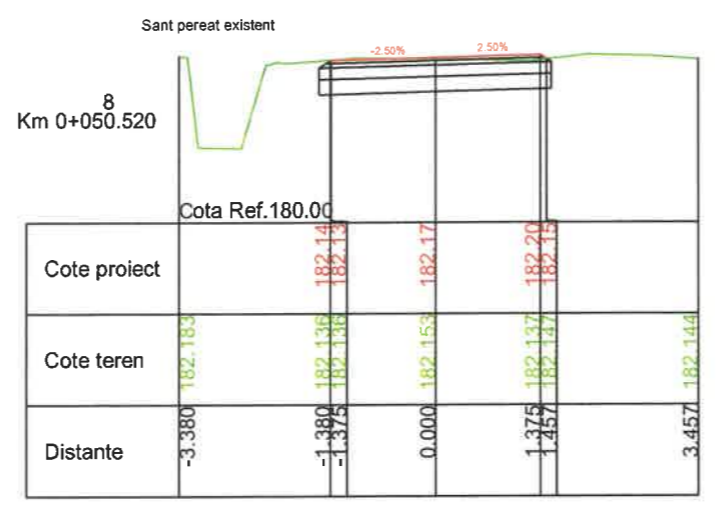
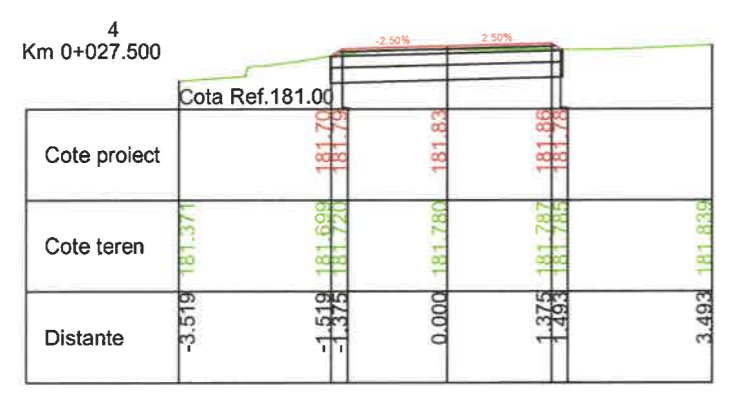

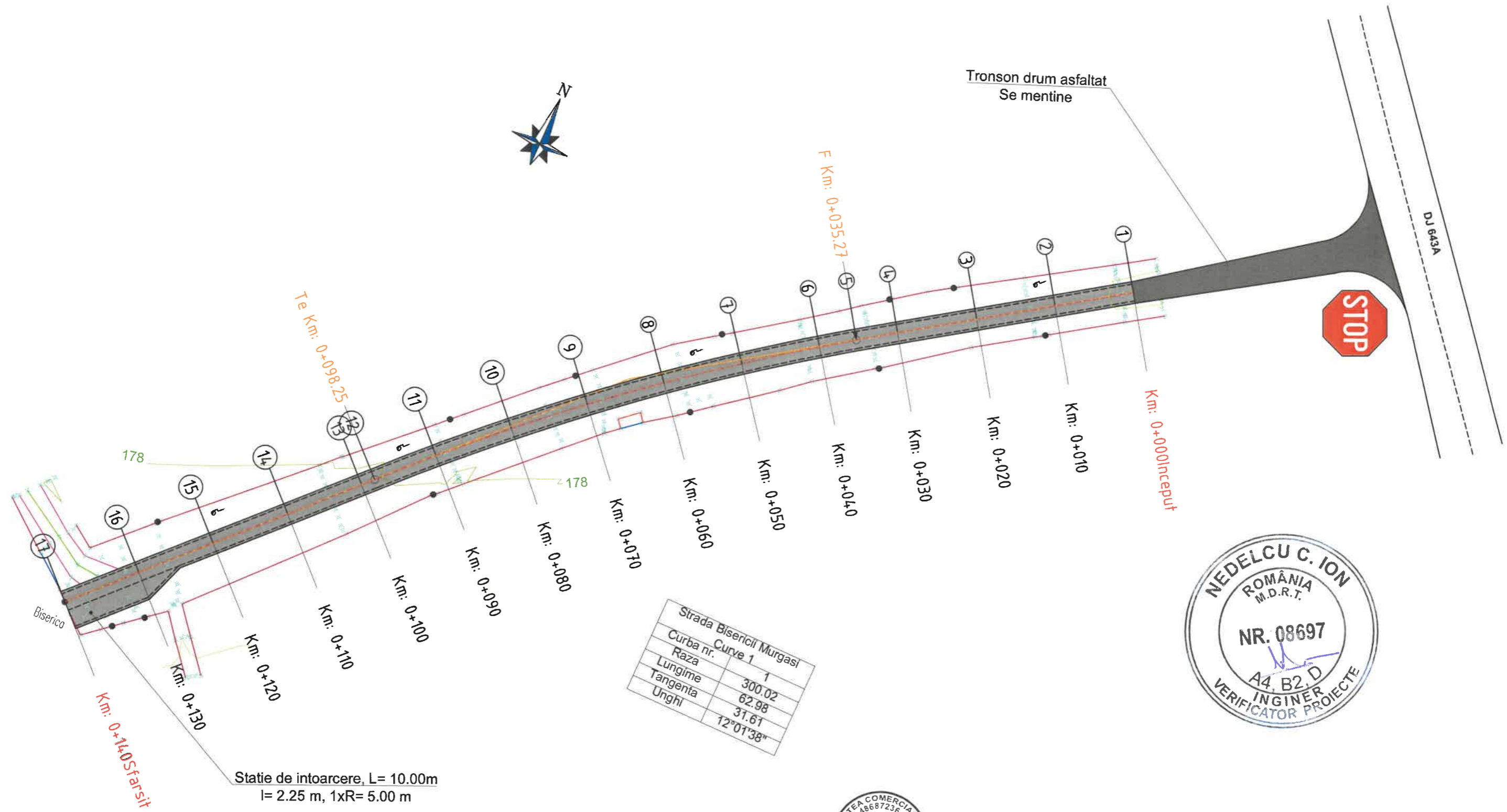

SCHEMA DE ASAMBLARE A PLANURILOR



LEGENDA:

- Punct topografic
- Parte carosabila si marcaj rutier
- Ax drum proiectat
- Aerisitor instalatie gaze naturale
- Camin utilitati
- Stalp electric
- Rigola acostament
- Sant perat
- Rigola carosabila

ROAD VISION DESIGN SRL Str. G. Mihail Cerchez, Nr. 10, Bl. A9, Ap. 3, CRAIOVA, Judetul DOLJ J16 / 1802 / 2023, CUI - RO48687236			Beneficiar:	Comuna Murgasi, Judetul Dolj	Proiect nr. 7 / 2023
SPECIFICATIE	NUME	SEMNATURA	Scara:	Titlu proiect:	Faza:
SEF PROIECT	ing. Mihai Sorin		1:500	MODERNIZARE INFRASTRUCTURA RUTIERA COMUNA MURGASI, JUDETUL DOLJ	P.T.Ex.
PROIECTAT	ing. Mihai Sorin		Data:	Titlu planșa:	Planșa nr.
DESENAT	ing. Rotaru Cristi		2023	PLAN DE SITUATIE Strada Bisericii Murgasi	02-PS-05-01
VERIFICAT	ing. Stavaru Bogdan				



BENEFICIAR:

**Comuna Murgasi,
Judetul Dolj**

DENUMIREA PROIECTULUI:

**Modernizare infrastructura rutiera
comuna Murgasi, Judetul Dolj**

PROIECTANT:

**ROAD VISION
DESIGN SRL**
Str. G. Mihail Carchez, Nr. 10, Bl. A9, Ap. 3,
CRAIOVA, judetul DOLJ
16 / 1802 / 2023, CUI - RO48687236



LEGENDA:

 Linie proiect
 Linie teren
 Linie sant dreapta
 Linie sant stanga

● KM =0+053.22
 mi (%) =12.50
 me (%) =11.20
 m (%) =1.30
 R (m) =2860
 T (m) =18.58
 B (cm) =6.03
 L (m) =37.16
 Schimbator panou

VERIFICATOR:

SEMNTURA

CERINTA: A4, B2, D

EXPERT:

SEMNTURA

CERINTA: A4, B2, D

SEF PROIECT
 Ing. Mihai Sorin

Proiectat Ing. Mihai Sorin 	Desenat Ing. Rotaru Cristi
-----------------------------------	-----------------------------------

TITLU PLANSA:

**PROFIL LONGITUDINAL
Strada Bisericii Murgasi**

SCARA:
 1:1000-L
 1:100-H

PROIECT: 7/2023

DATA: 2023

FAZA DE PROIECTARE P.T.Ex.

PLANSA NR. 03-PL-05-01

REVIZIA NR. 0

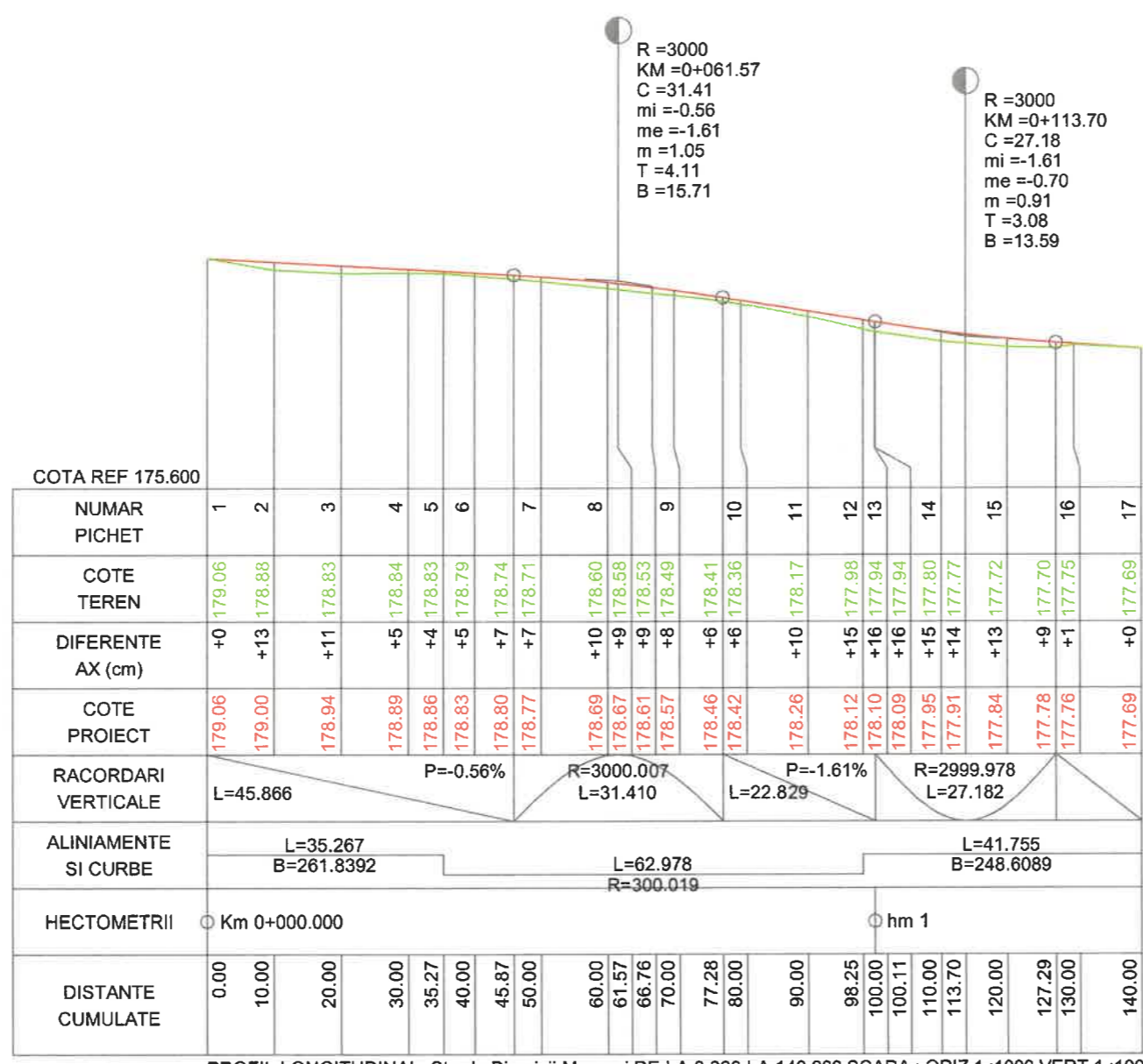

PROFIL LONGITUDINAL Strada Bisericii Murgasi DE LA 0.000 LA 140.000 SCARA : ORIZ 1 :1000 VERT 1 :100



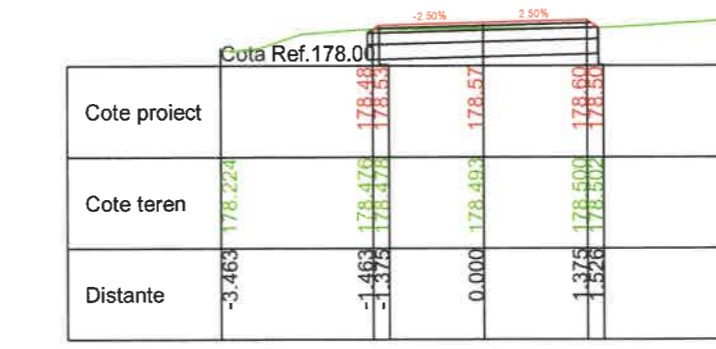
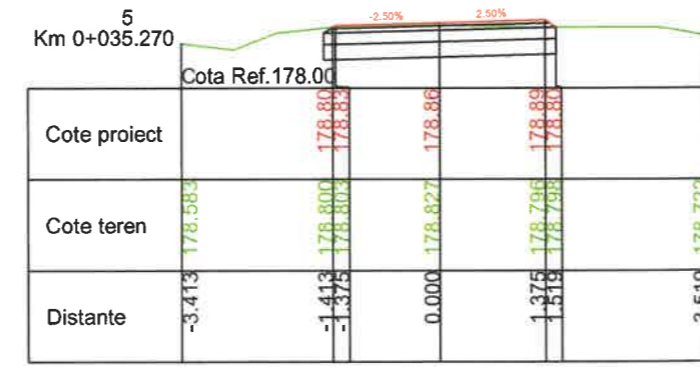
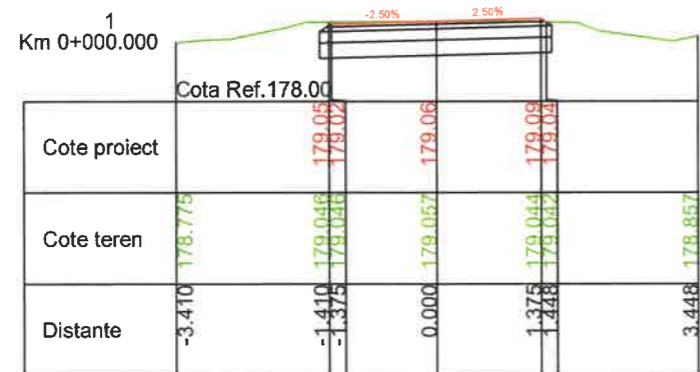
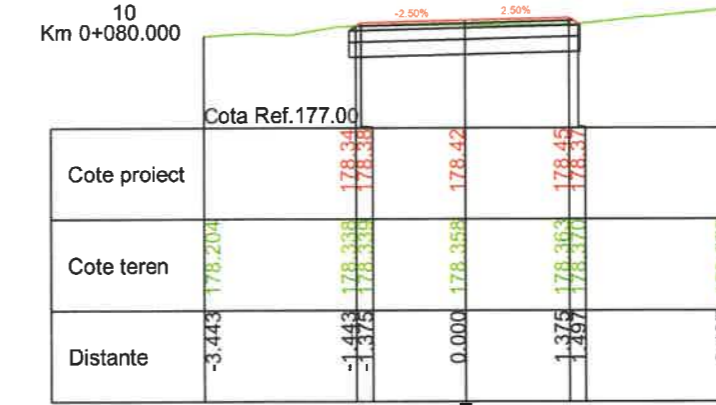
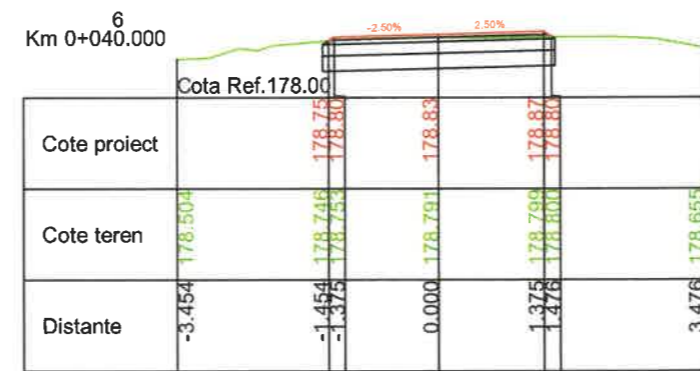
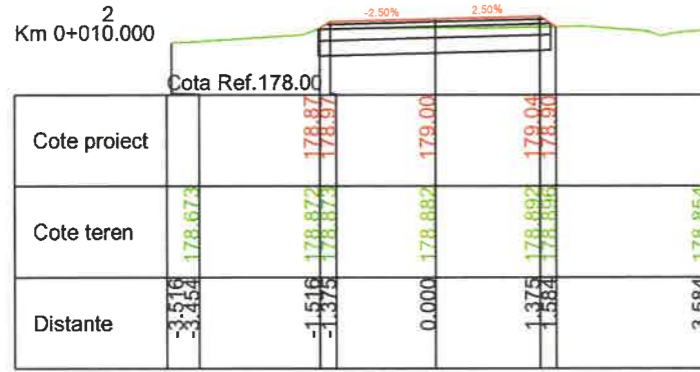
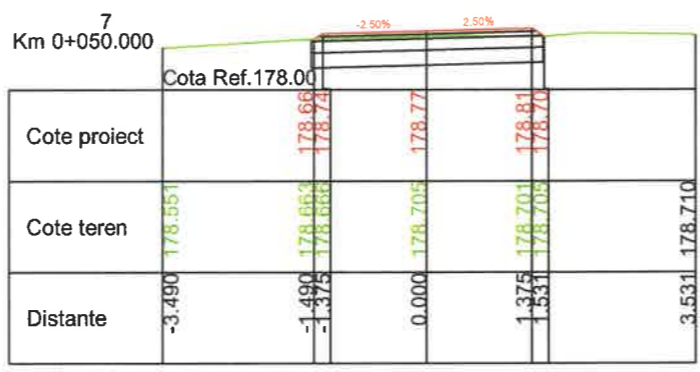
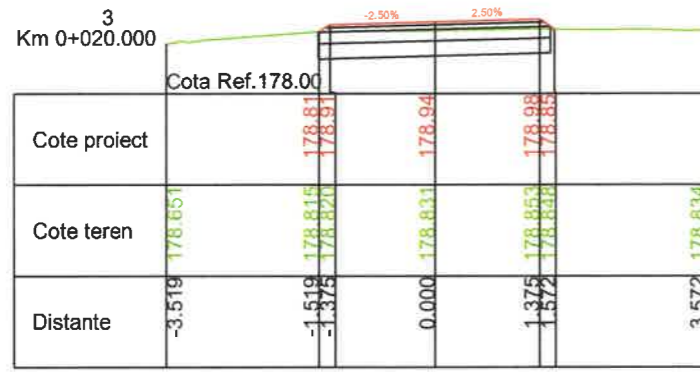
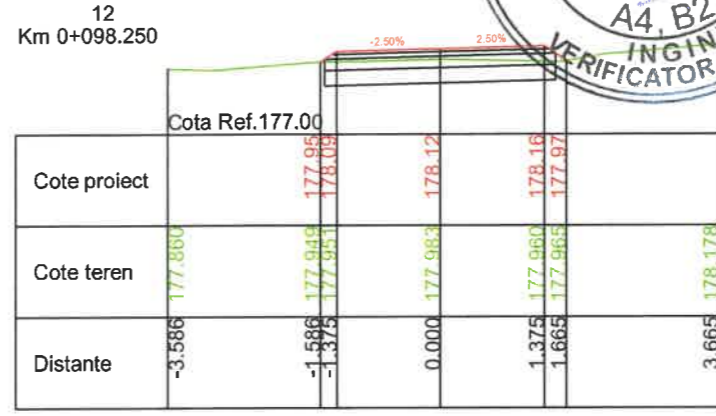
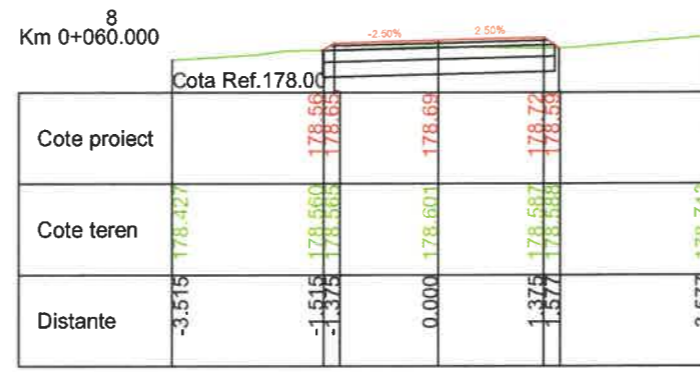
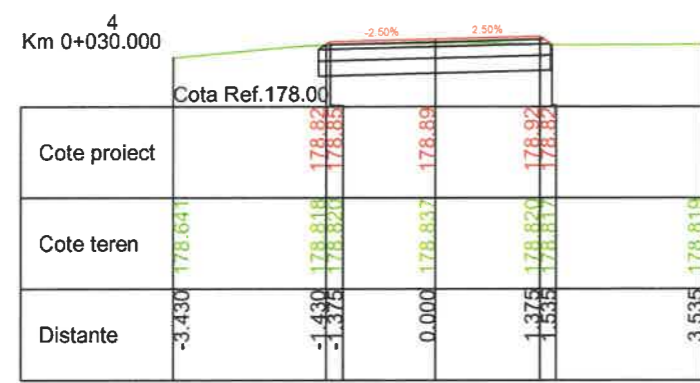

BENEFICIAR:	
Comuna Murgasi, Judetul Dolj	
DENUMIREA PROIECTULUI:	
Modernizare infrastructura rutiera comuna Murgasi, Judetul Dolj	
PROIECTANT:	
ROAD VISION DESIGN S.R.L. Craiova	
LEGENDA:	
— Linie proiect	
— Linie teren	
VERIFICATOR:	
SEMNATURA	
CERINTA: A4, B2, D	
EXPERT:	
SEMNATURA	
CERINTA: A4, B2, D	
SEF PROIECT	
Ing. Mihai Sorin	
Proiectat	Desenat
Ing. Mihai Sorin	Ing. Rotaru Cristi
TITLU PLANSA:	
PROFILE TRANSVERSALE Strada Bisericii Gaia - Tronson 2	
SCARA:	
1:100	
PROIECT:	7/2023
DATA:	2023
FAZA DE PROIECTARE	P.T.Ex.
PLANSĂ NR.	04-PT-05-01
REVIZIA NR.	0



16
Km 0+130.000

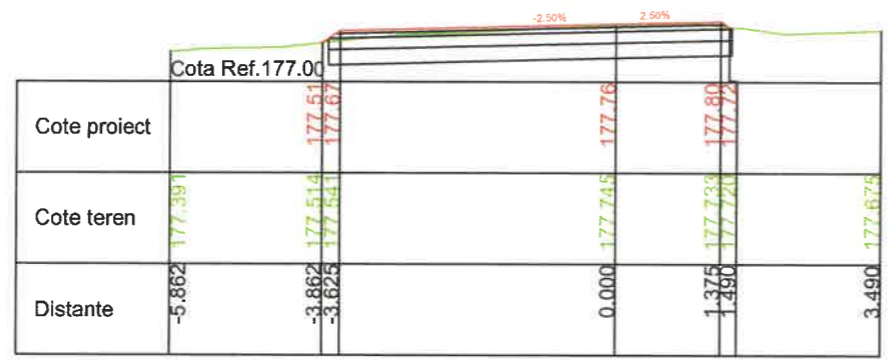

15
Km 0+120.000

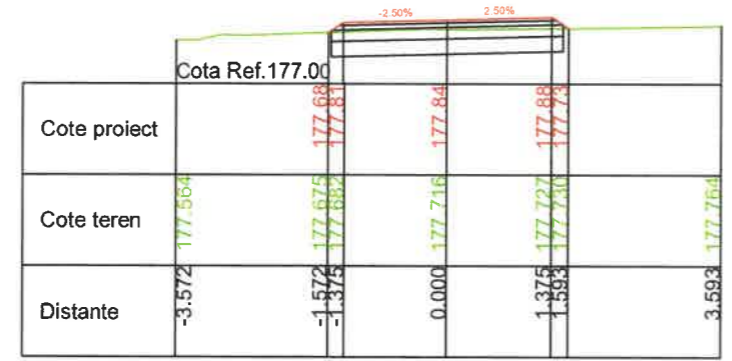

14
Km 0+110.000

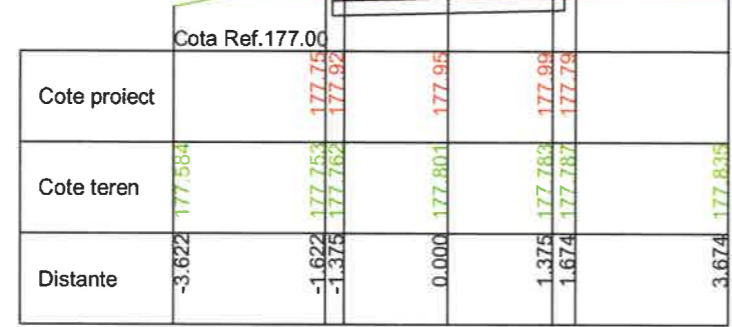

13
Km 0+100.000

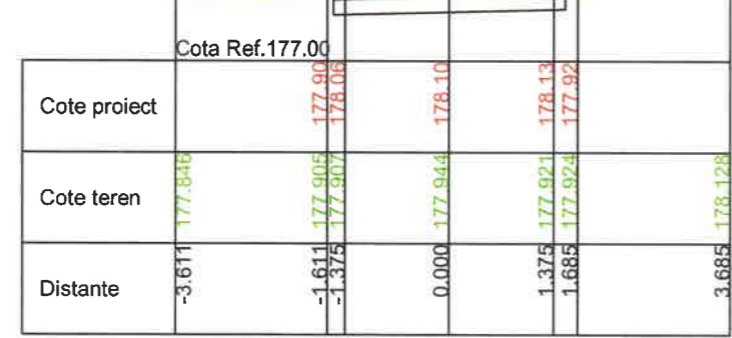

17
Km 0+140.000

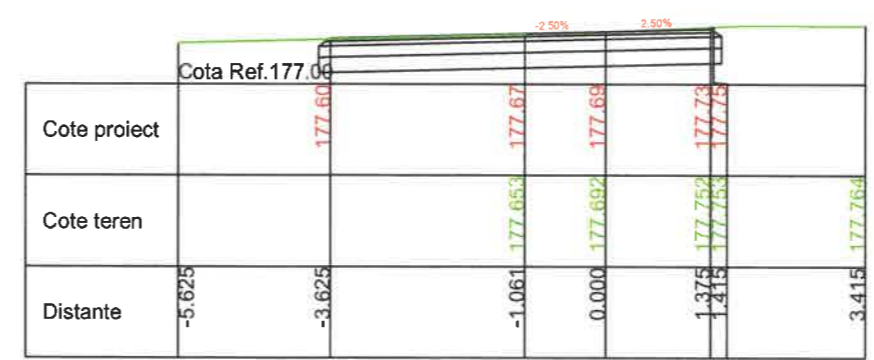

BENEFICIAR:
Comuna Murgasi, Judetul Dolj

DENUMIREA PROIECTULUI:
Modernizare infrastructura rutiera comuna Murgasi, Judetul Dolj

PROIECTANT:



LEGENDA:
 Linie proiect
 Linie teren



VERIFICATOR:
SEMNATURA
CERINTA: A4, B2, D

EXPERT:
SEMNATURA
CERINTA: A4, B2, D

SEF PROIECT
Ing. Mihai Sorin

Proiectat **Ing. Mihai Sorin** Desenat **Ing. Rotaru Cristi**

TITLU PLANSA:
PROFILE TRANSVERSALE Strada Bisericii Gaia - Tronson 2

SCARA:
1:100

PROIECT:	7/2023
DATA:	2023
FAZA DE PROIECTARE	P.T.Ex.
PLANSA NR.	04-PT-05-02
REVIZIA NR.	0

PROFIL TRANSVERSAL TIP 1

STRUCTURA RUTIERA NOUA

Se aplica:

DC 128A:
 Strada BISERICII BUSTENI:
 Strada BISERICII GAIA-TRONSON 2:
 Strada BISERICII MURGASI:

Km 0+000 - Km 0+145
 Km 0+000 - Km 0+045
 Km 0+000 - Km 0+070
 Km 0+000 - Km 0+140

Clasa tehnica: V
 Viteza de proiectare: 25 Km/h
 Cerinte de verificare: A4, B2, D

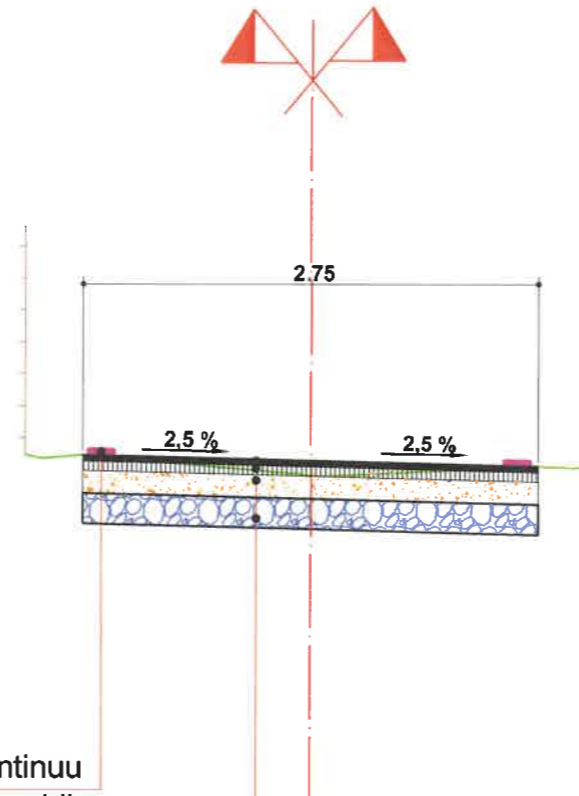



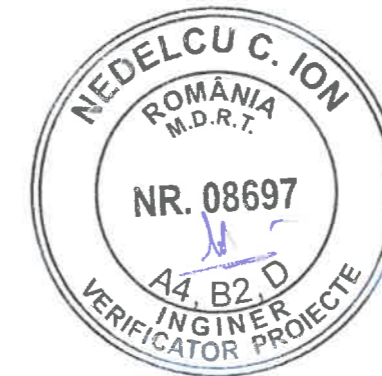

Marcaj longitudinal discontinuu
 pentru delimitarea partii carosabile



STRUCTURA RUTIERA NOUA

- 4 cm strat de uzura din BAPC 16, conform SR EN 13108-1 si AND 605/2016;
- 6 cm strat de legatura din BADPC 22.4, conform SR EN 13108-1 si AND 605/2016;
- 15 cm strat superior de fundatie din piatra sparta, conform STAS 6400 si SR EN 13242;
- 20 cm strat inferior de fundatie din balast, conform STAS 6400 si SR EN 13242.



 ROAD VISION DESIGN SRL Str. G. Mihail Cerchez, Nr. 10, Bl. A9, Ap. 3, CRAIOVA, judetul DOLJ J16 / 1802 / 2023, CUI - RO48687236		Beneficiar: Comuna Murgasi, Judetul Dolj	Proiect nr. 7 / 2023		
SPECIFICATIE	NUME	SEMNATURA	Scara:	Titlu proiect: MODERNIZARE INFRASTRUCTURA RUTIERA COMUNA MURGASI, JUDETUL DOLJ	Faza: P.T.Ex.
SEF PROIECT	ing. Mihai Sorin		1:50		
PROIECTAT	ing. Mihai Sorin			Titlu plansa: PROFIL TRANSVERSAL TIP 1	Plansa nr. 05-PTT-01
DESEINAT	ing. Rotaru Cristi		Data: 2023		
VERIFICAT	ing. Stavaru Bogdan				

PROFIL TRANSVERSAL TIP 2

STRUCTURA RUTIERA NOUA

Se aplica:
Strada FANTANITEI: Km 0+000 - Km 0+298

Clasa tehnica: V
Viteza de proiectare: 25 Km/h
Cerinte de verificare: A4, B2, D

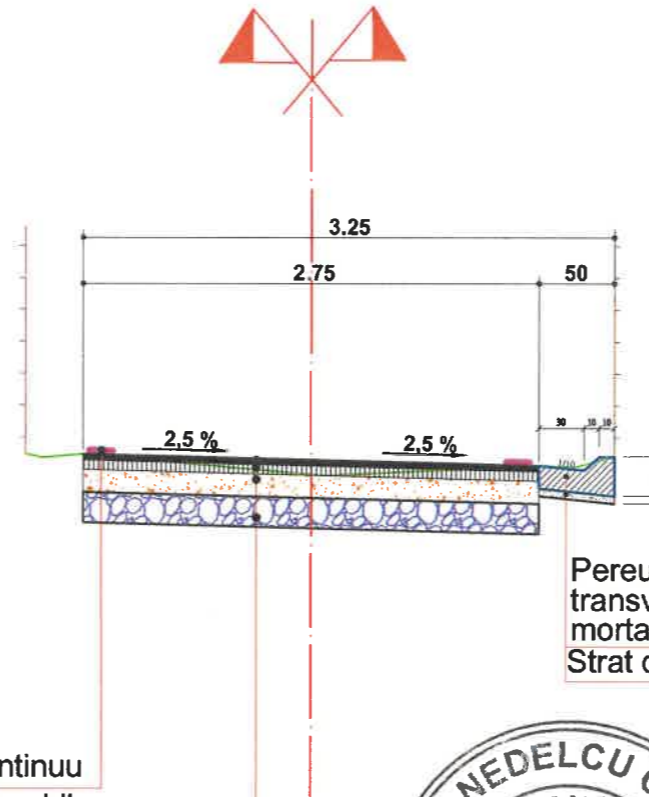





Pereu din beton de ciment C 30/37 de 15 cm grosime, turnat cu rosturi transversale de 2.5 cm grosime, amplasate la 200 cm si matate cu mortar de ciment M 100Z pe 4 cm si nisip pe 16 cm.
Strat de nisip, in grosime de 5 cm dupa pilonare

Marcaj longitudinal discontinuu
pentru delimitarea partii carosabile

STRUCTURA RUTIERA NOUA

4 cm strat de uzura din BAPC 16, conform SR EN 13108-1 si AND 605/2016;
6 cm strat de legatura din BADPC 22.4, conform SR EN 13108-1 si AND 605/2016;
15 cm strat superior de fundatie din piatra sparta, conform STAS 6400 si SR EN 13242;
20 cm strat inferior de fundatie din balast, conform STAS 6400 si SR EN 13242.



 ROAD VISION DESIGN SRL Str. G. Mihail Cerchez, Nr. 10, Bl. A9, Ap. 3, CRAIOVA, judetul DOLJ J16 / 1802 / 2023, CUI - RO48687236				Beneficiar:	Proiect nr.
				Comuna Murgasi, Judetul Dolj	7 / 2023
SPECIFICATIE	NUME	SEMNATURA	Scara:	Titlu proiect:	Faza:
SEF PROIECT	ing. Mihai Sorin		1:50	MODERNIZARE INFRASTRUCTURA RUTIERA COMUNA MURGASI, JUDETUL DOLJ	P.T.Ex.
PROIECTAT	ing. Mihai Sorin				
DESENAT	ing. Rotaru Cristi		Data:	Titlu plansa:	Plansa nr.
VERIFICAT	ing. Stavaru Bogdan		2023	PROFIL TRANSVERSAL TIP 2	05-PTT-02

PROFIL TRANSVERSAL TIP 3

STRUCTURA RUTIERA NOUA

Se aplica:
Strada FANTANITEI: Km 0+298 - Km 0+325

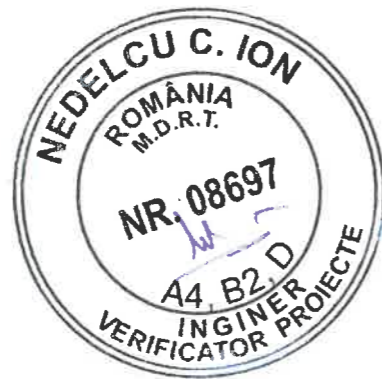

Marcaj longitudinal discontinuu
pentru delimitarea partii carosabile

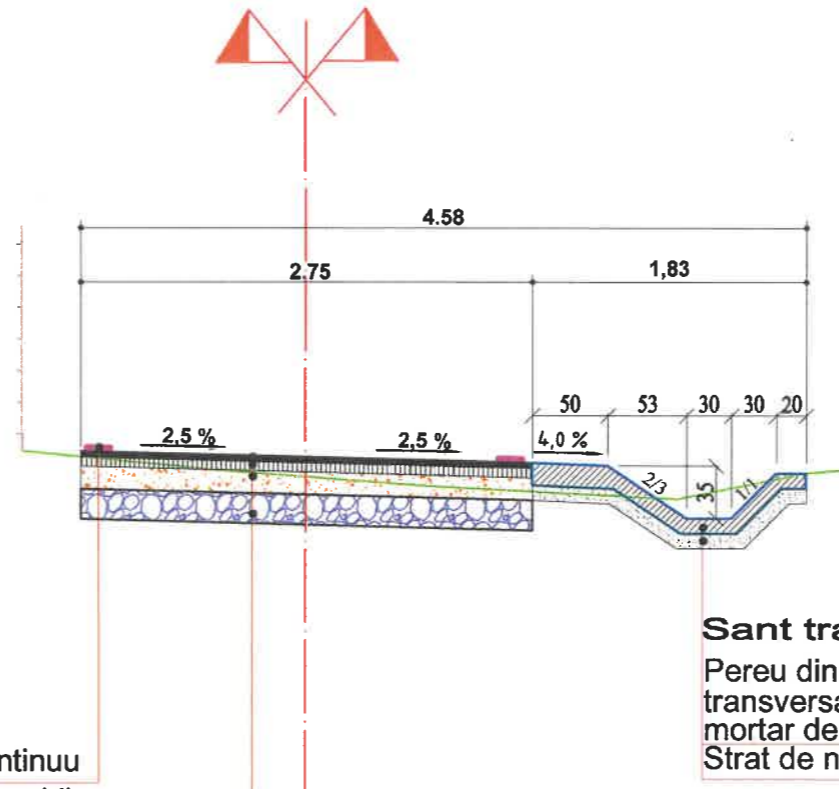

Clasa tehnica: V
Viteza de proiectare: 25 Km/h
Cerinte de verificare: A4, B2, D

Sant trapezoidal peret

Pereu din beton de ciment C 30/37 de 10 cm grosime, turnat cu rosturi transversale de 2.5 cm grosime, amplasate la 200 cm si matate cu mortar de ciment M 100Z pe 4 cm si nisip pe 6 cm.
Strat de nisip/balast, in grosime de 10 cm dupa pilonare

STRUCTURA RUTIERA NOUA

4 cm strat de uzura din BAPC 16, conform SR EN 13108-1 si AND 605/2016;
6 cm strat de legatura din BADPC 22.4, conform SR EN 13108-1 si AND 605/2016;
15 cm strat superior de fundatie din piatra sparta, conform STAS 6400 si SR EN 13242;
20 cm strat inferior de fundatie din balast, conform STAS 6400 si SR EN 13242.



ROAD VISION DESIGN SRL Str. G. Mihail Cerchez, Nr. 10, Bl. A9, Ap. 3, CRAIOVA, judetul DOLJ J16 / 1802 / 2023, CUI - RO48687236				Beneficiar:	Proiect nr.
				Comuna Murgasi, Judetul Dolj	7 / 2023
SPECIFICATIE	NUME	SEMNATURA	Scara:	Titlu proiect:	Faza:
SEF PROIECT	Ing. Mihai Sorin		1:50	MODERNIZARE INFRASTRUCTURA RUTIERA COMUNA MURGASI, JUDEUL DOLJ	P.T.Ex.
PROIECTAT	Ing. Mihai Sorin				
DESENAT	Ing. Rotaru Cristi		Data:	Titlu plansa:	Plansa nr.
VERIFICAT	Ing. Stavaru Bogdan		2023	PROFIL TRANSVERSAL TIP 3	05-PTT-03

DETALII PODET TUBULAR

SECTIUNE LONGITUDINALA

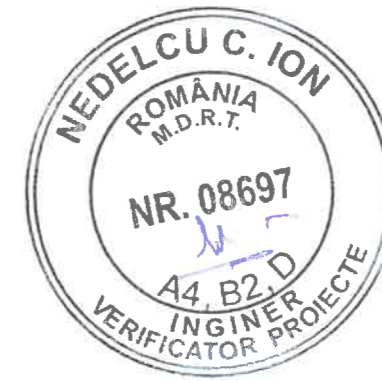
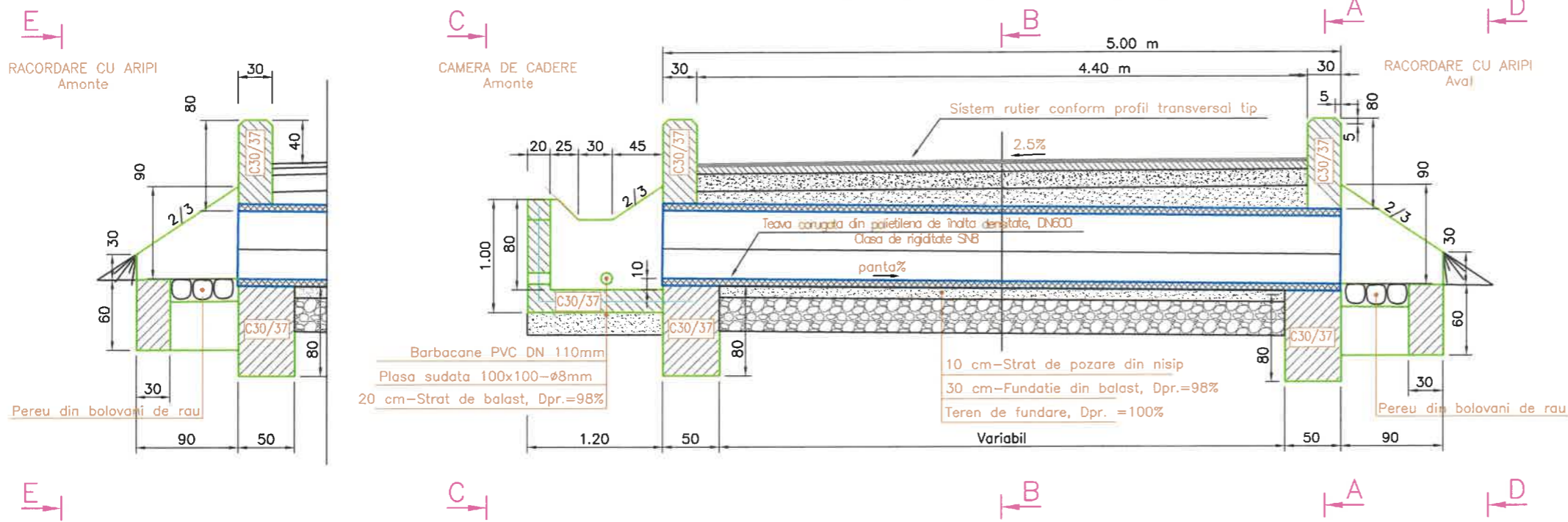

- Materiale:**
- Fundatie-beton de ciment clasa C30/37
 - Elevatie-beton de ciment clasa C30/37 (clasele de expunere XC4+XF2)
 - Balast (amestec agregat sort 0-63mm)
 - Nisip

SECTIUNE A-A

SECTIUNE B-B

VEDERE C-C

VEDERE D-D

VEDERE E-E

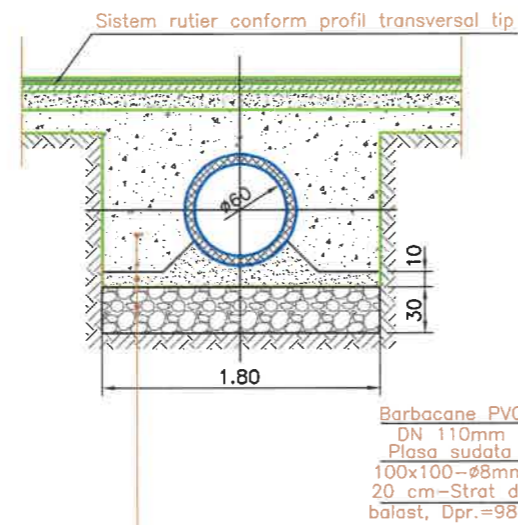
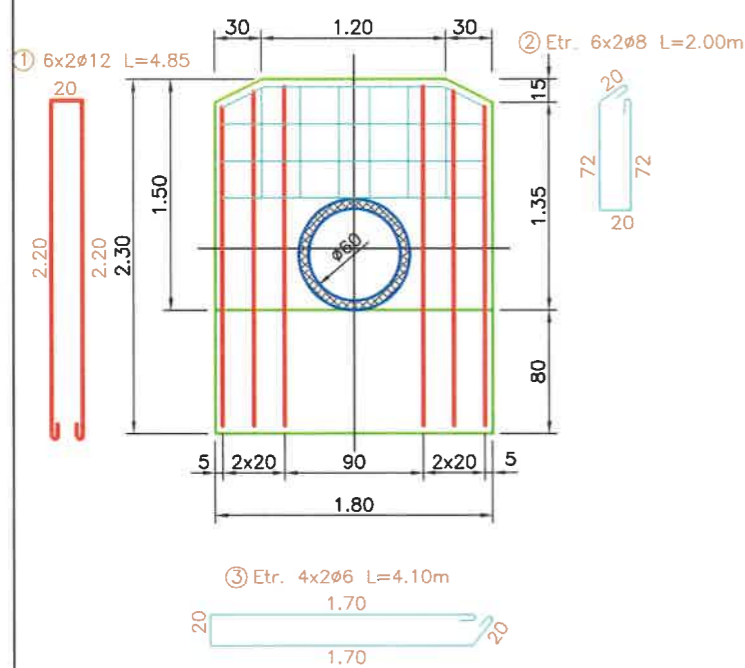

- Umplutura compactata Dpr=96%**
10 cm-Strat de pozare din nisip
30 cm-Fundatie din balast, Dpr.=98%
Teren de fundare, Dpr. =100%



ROAD VISION DESIGN SRL Societate Comerciala cu CUI 18687236 G. Mihail Cerchez, Nr. 10, Bl. A9, Ap. 3, CRAIOVA, judetul DOLJ J16 / 1802 / 2023, CUI - RO48687236				Beneficiar: Comuna Murgasi, Judetul Dolj	Proiect nr. 7 / 2023
SPECIFICATIE	NUME	SEMNATURA	Scara:	Titlu proiect:	Faza:
SEF PROIECT	ing. Mihai Sorin	<i>Mihai Sorin</i>	1:50	MODERNIZARE INFRASTRUCTURA RUTIERA COMUNA MURGASI, JUDETUL DOLJ	P.T.Ex.
PROIECTAT	ing. Mihai Sorin	<i>Mihai Sorin</i>	Data:		
DESENAT	ing. Rotaru Cristi	<i>Rotaru Cristi</i>	2023	Titlu plansa:	Plansa nr.
VERIFICAT	ing. Stavaru Bogdan	<i>Stavaru Bogdan</i>		PODET TUBULAR Ø=0.600 m	06-TUB-01

SECTIUNE LONGITUDINALA A-A

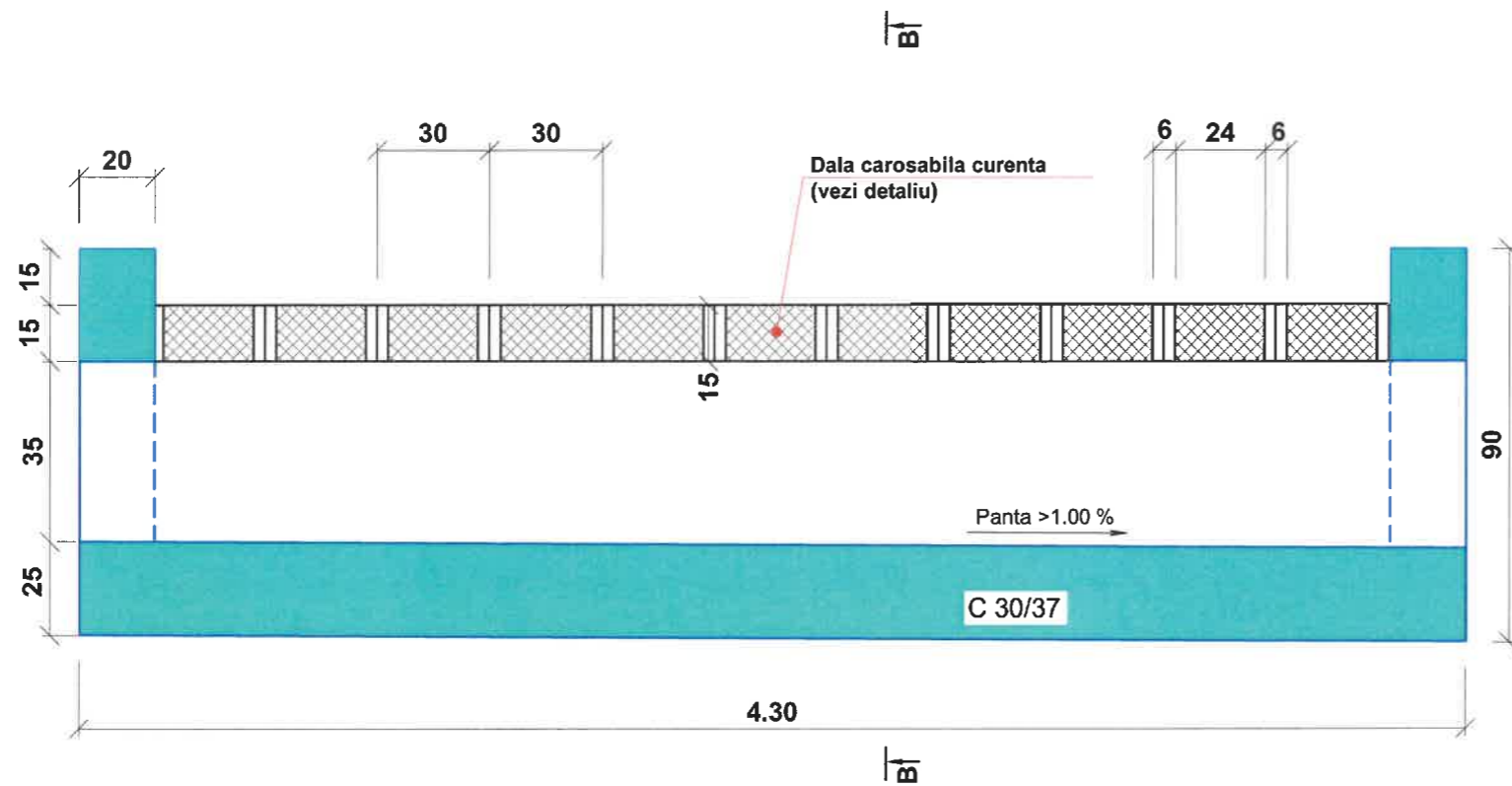



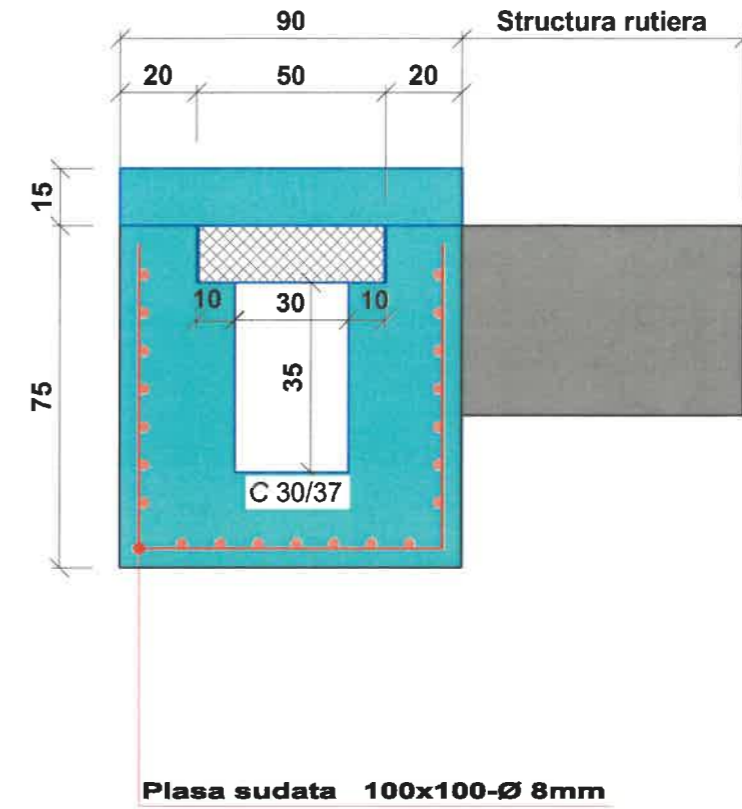

SECTIUNE TRANSVERSALA B-B

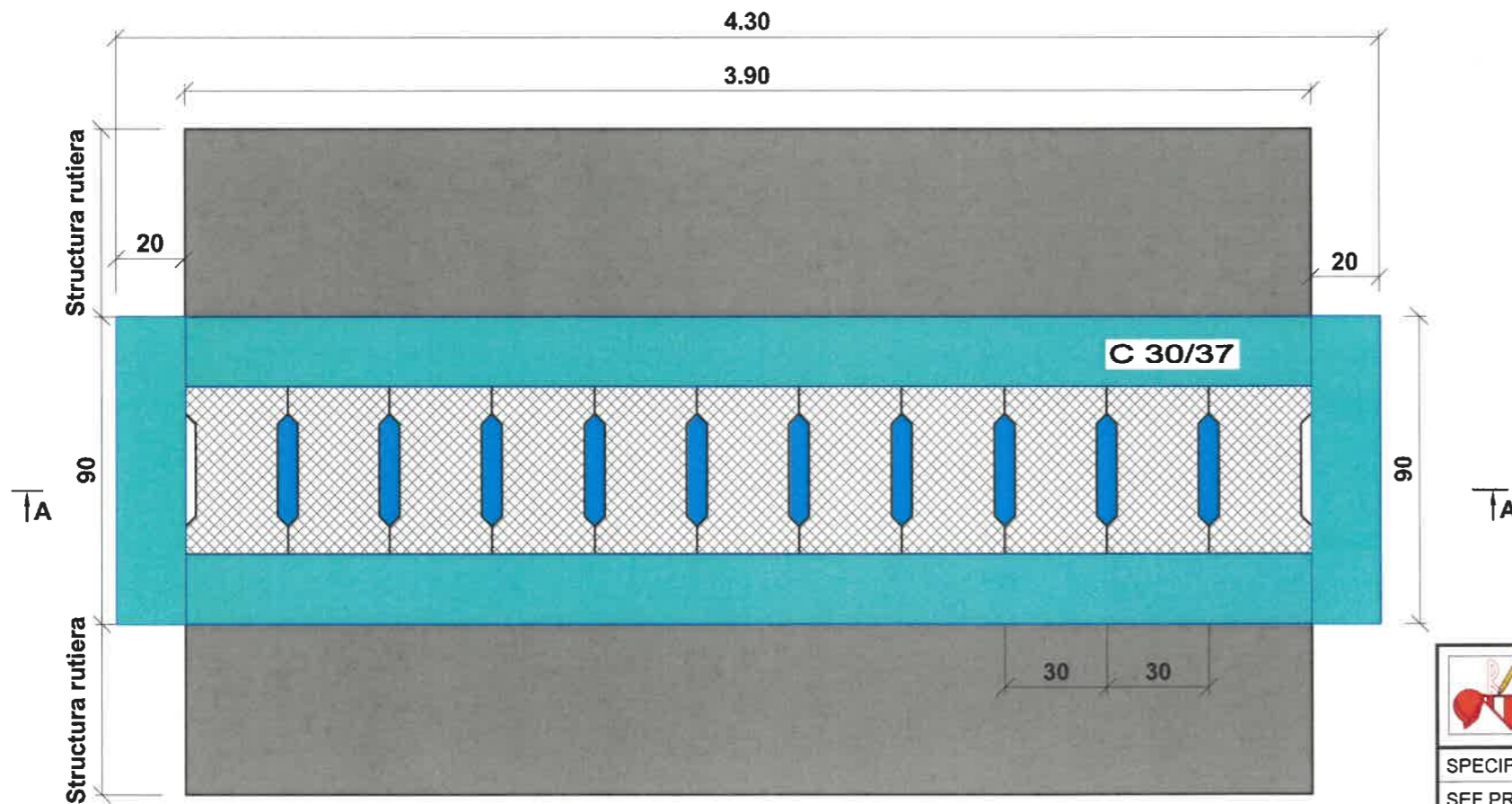

VEDERE PLANA

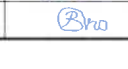

 ROAD VISION DESIGN SRL Str. G. Mihail Caraculaz, Nr. 10, Bl. A9, Ap. 3, CRAIOVA, judetul DOLJ J16 / 1802 / 2023, CUI - RO48687236		Beneficiar: Comuna Murgasi, Judetul Dolj	Proiect nr. 7 / 2023		
SPECIFICATIE	NUME	SEMNATURA	Scara:	Titlu proiect:	Faza:
SEF PROIECT	ing. Mihai Sorin		1:20	MODERNIZARE INFRASTRUCTURA RUTIERA COMUNA MURGASI, JUDETUL DOLJ	P.T.Ex.
PROIECTAT	ing. Mihai Sorin		Data:	Titlu plansa:	Plansa nr.
DESEINAT	ing. Rotaru Cristi		2023	RIGOLA CAROSABILATIP PODET Dispozitie generala	06-RCTP-01
VERIFICAT	ing. Stavaru Bogdan				

DALA CAROSABILA CURENTA DIN BETON ARMAT PLAN COFRAJ

SCARA 1:10

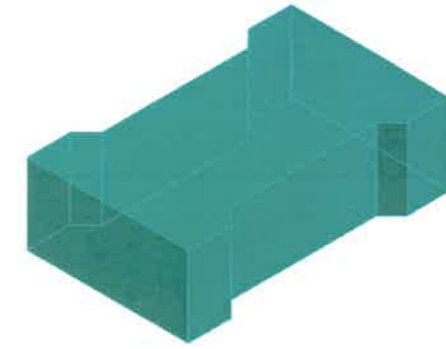

VEDERE PLANA

VEDERE B-B

SECTIUNE C-C

SECTIUNE D-D

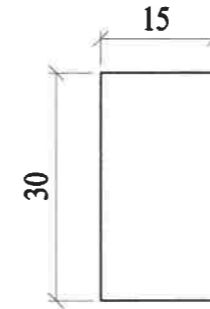
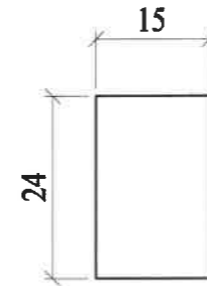
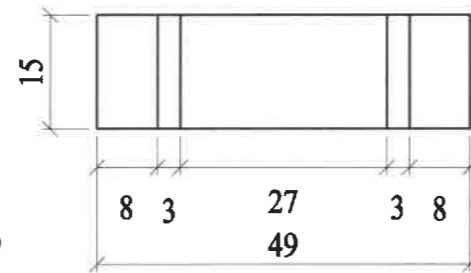
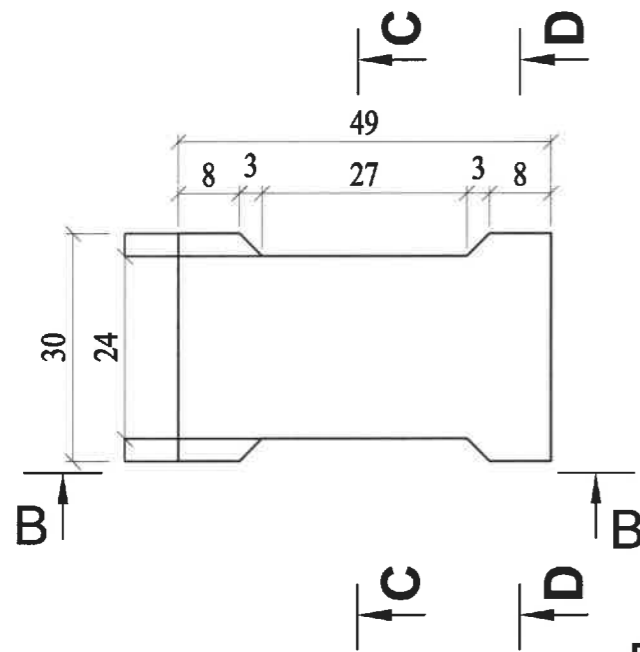

CLASA DE SARCINA D400
(CAPACITATEA DE INCARCARE 400 kN)

OTEL BETON OB37

Volum beton = 0,019 mc/buc

Masa = 47.50 kg/buc

Otel beton = 5,62 kg/buc

PLAN ARMARE SCARA 1:10

SECTIUNE B-B

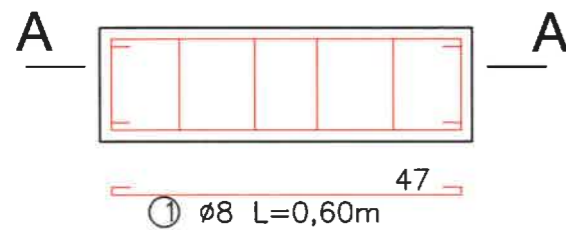

SECTIUNE A-A

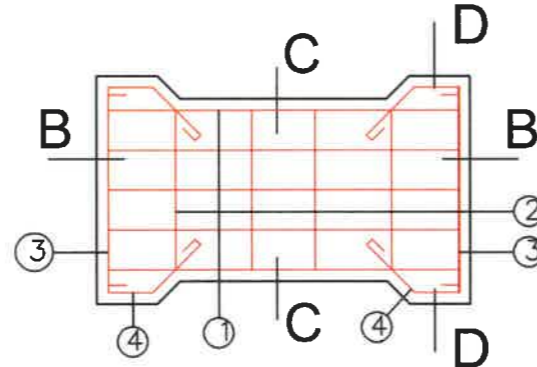

SECTIUNE C-C

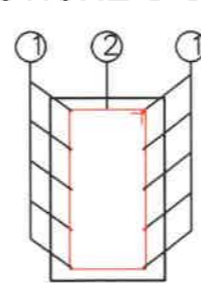

SECTIUNE D-D

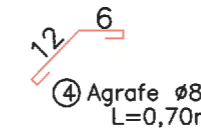
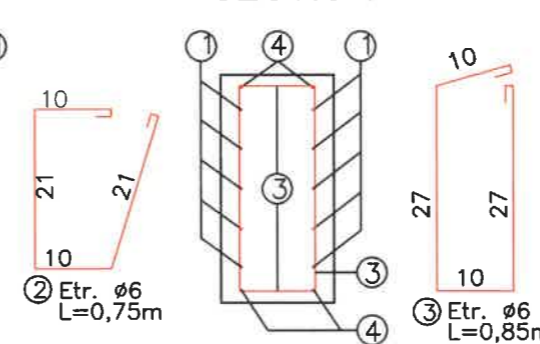

EXTRAS DE ARMATURA
pentru o placuta

Element	Marca	Diametru	Nr.de bare	Lungimea unei bare	Lungimea (m)	
					OTEL OB37 ø6	ø8
PLACUTA	1	8	10	.60	3.00	6.00
	2	6	4	.75	1.70	
	3	6	2	.85		
	4	8	8	.70		5.60
Total lungimi pe diametre (m)					4.70	11.60
Masa pe metru (Kg/m)					.222	.395
Masa pe diametre (Kg)					1.04	4.58
Masa totala pe tip de otel (Kg)					5.62	



ROAD VISION DESIGN SRL

Str. G. Mihail Cerchez, Nr. 10, Bl. A9, Ap. 3, CRAIOVA, judetul DOLJ
J16 / 1802 / 2023, CUI - RO48687236

Beneficiar:	Comuna Murgasi, Judetul Dolj	Proiect nr.	7 / 2023
Titlu proiect:	MODERNIZARE INFRASTRUCTURA RUTIERA COMUNA MURGASI, JUDETUL DOLJ	Faza:	P.T.Ex.
Titlu plansa:	RIGOLA CAROSABILA TIP PODET Detaliu cofraj si armare dala carosabila curenta	Plansa nr.	06-RCTP-02

SPECIFICATIE	NUME	SEMNATURA	Scara:
SEF PROIECT	ing. Mihai Sorin	<i>Mihai Sorin</i>	1:10
PROIECTAT	ing. Mihai Sorin	<i>Mihai Sorin</i>	
DESENAT	ing. Rotaru Cristi	<i>Rotaru Cristi</i>	Data:
VERIFICAT	ing. Stavaru Bogdan	<i>Stavaru Bogdan</i>	2023

DETALIU MARCAJE RUTIERE

Scara 1:500

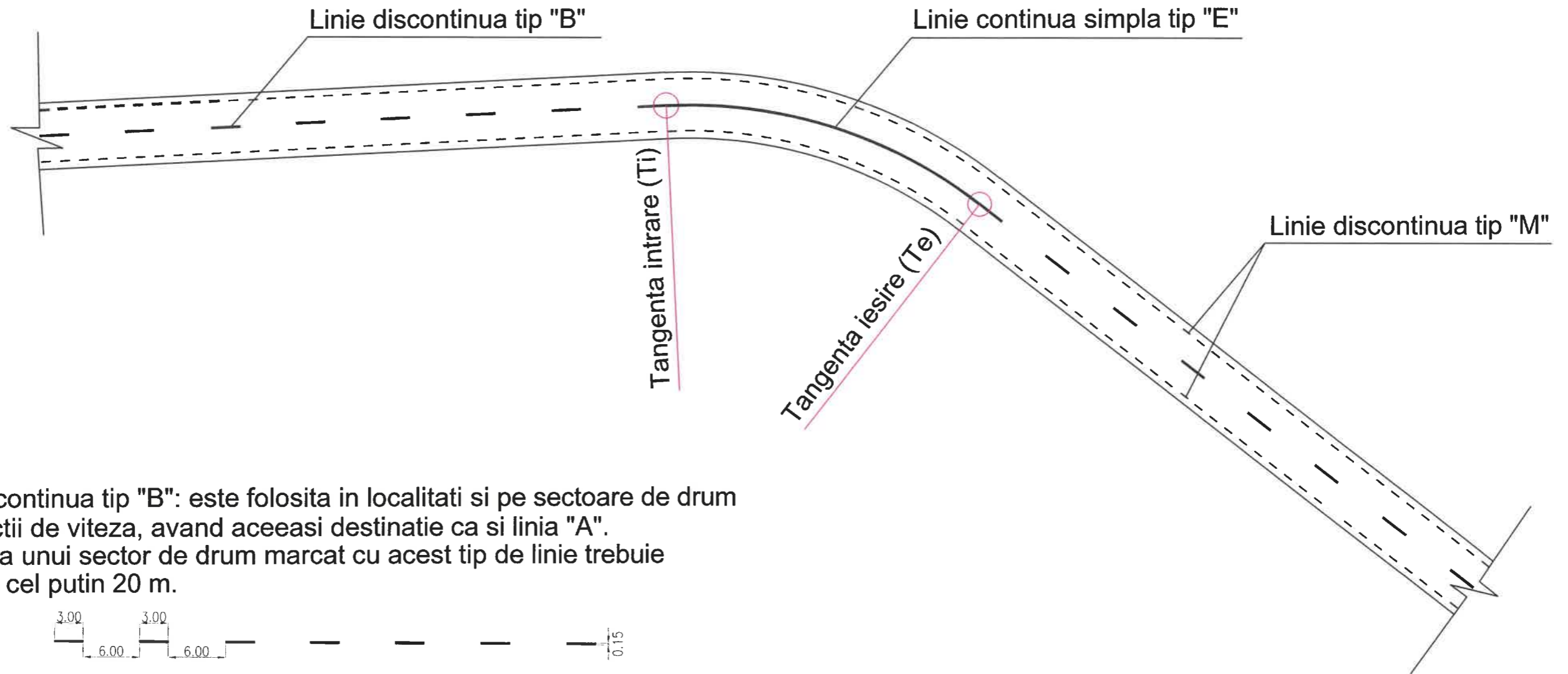

Linia discontinua tip "B": este folosita in localitati si pe sectoare de drum cu restrictii de viteza, avand aceeasi destinatie ca si linia "A". Lungimea unui sector de drum marcat cu acest tip de linie trebuie sa fie de cel putin 20 m.



Linia continua simpla tip "E": este folosita pentru separarea sensurilor de circulatie, pentru separarea benzilor de acelasi sens la apropierea de intersectii si in zone periculoase.



Linia discontinua simpla tip "M": avand segmentele si intervalele de 1.00 m, se foloseste in afara localitatii atunci cand nu sunt asigurate benzi de urgenta (acostamentele au latimi sub 2.50 m) precum si pe sectoarele situate in localitati.

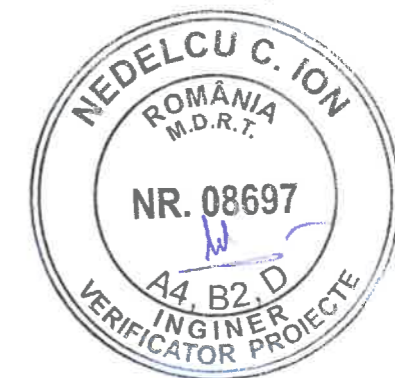
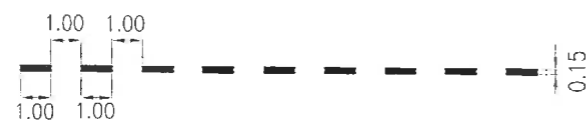

Nota: Marcajele rutiere longitudinale se vor executa mecanizat cu vopsea de email, fara microbule de sticla, cu latimea de 15 cm, conform **SR 1848-7/2015**



ROAD VISION DESIGN SRL Str. G. Mihail Cerchez, Nr. 10, Bl. A9, Ap. 3, CRAIOVA, judetul DOLJ J16 / 1802 / 2023, CUI - RO48687236			Beneficiar:	Comuna Murgasi, Judetul Dolj	Proiect nr. 7 / 2023
SPECIFICATIE	NUME	SEMNATURA	Scara:	Titlu proiect:	Faza:
SEF PROIECT	ing. Mihai Sorin		1:500	MODERNIZARE INFRASTRUCTURA RUTIERA COMUNA MURGASI, JUDETUL DOLJ	P.T.Ex.
PROIECTAT	ing. Mihai Sorin		Data:	Titlu plansa:	Plansa nr.
DESENAT	ing. Rotaru Cristi		2023	MARCAJE RUTIERE LONGITUDINALE	08-MRL-01
VERIFICAT	ing. Stavaru Bogdan				

INDICATOARE DE REGLEMENTARE

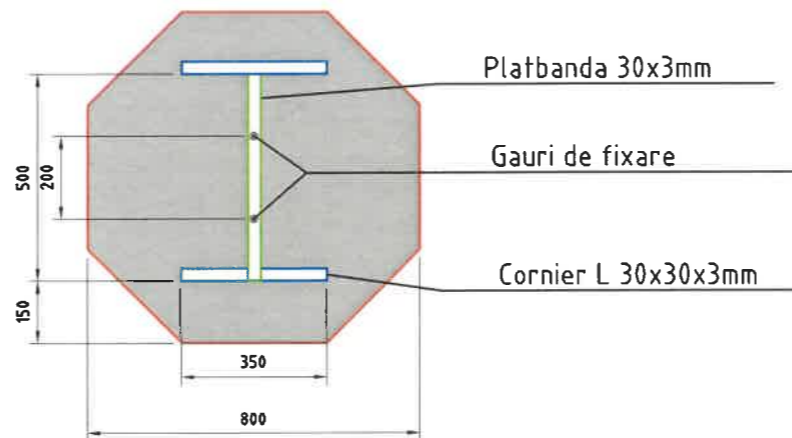
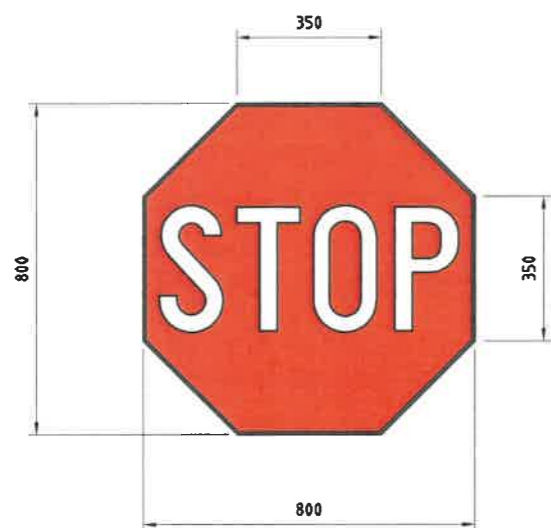

DISPOZITIV SI MODUL DE PRINDERE A INDICATOARELOR PE STALP

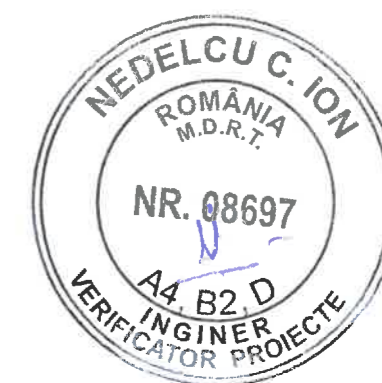
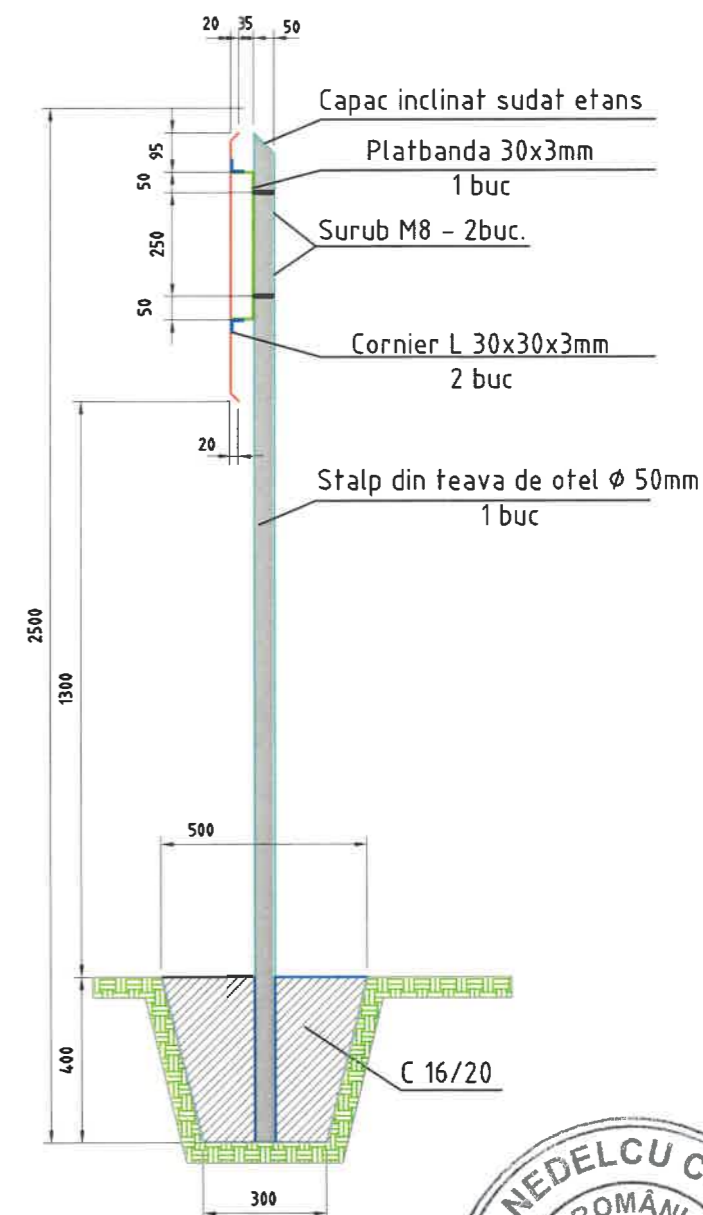

NOTA:
 1. Fetele indicatoarelor se vopsesc in culorile date de SR 1848/1-2011
 2. Spatele indicatoarelor , inclusiv canturile ambutisate si stalpii se vopsesc in culoare gri
 3. Indicatoarele se instaleaza pe partea dreapta a drumului, astfel incat sa asigure o buna vizibilitate a acestora

ROAD VISION DESIGN SRL Str. G. Mihail Cerchez, Nr. 10, Bl. A9, Ap. 3, CRAIOVA, judetul DOLJ J16 / 1802 / 2023, CUI - RO48687236			Beneficiar:	Proiect nr.	
			Comuna Murgasi, Judetul Dolj	7 / 2023	
SPECIFICATIE	NUME	SEMNATURA	Scara:	Titlu proiect:	Faza:
SEF PROIECT	ing. Mihai Sorin		1:20	MODERNIZARE INFRASTRUCTURA RUTIERA COMUNA MURGASI, JUDETUL DOLJ	P.T.Ex.
PROIECTAT	ing. Mihai Sorin				
DESEANAT	ing. Rotaru Cristi		Data:	Titlu plansa:	Plansa nr.
VERIFICAT	ing. Stavaru Bogdan		2023	INDICATOARE RUTIERE	09-IND-01